

USER'S MANUAL FOR  
*BEAM SECTION PROPERTIES*  
(BSP)



**pennsylvania**  
DEPARTMENT OF TRANSPORTATION

Version 2.0.0.0



**USER'S MANUAL FOR  
COMPUTER PROGRAM BSP  
BEAM SECTION PROPERTIES  
VERSION 2.0.0.0**

Prepared by:

Pennsylvania Department of Transportation  
Bureau of Business Solutions and Services  
Engineering Software Section

March 2015

## Beam Section Properties

This page is intentionally left blank.

**TABLE OF CONTENTS**

Chapter 1 - GENERAL DESCRIPTION..... 1-1  
    1.1 PROGRAM IDENTIFICATION ..... 1-1  
Chapter 2 - PROGRAM DESCRIPTION ..... 2-1  
    2.1 PROGRAM DESCRIPTION ..... 2-1  
Chapter 3 - METHOD OF SOLUTION..... 3-1  
    3.1 GENERAL ..... 3-1  
Chapter 4 - GETTING STARTED..... 4-1  
    4.1 INSTALLATION ..... 4-1  
    4.2 PREPARING INPUT ..... 4-2  
    4.3 ENGINEERING ASSISTANT ..... 4-2  
    4.4 RUNNING THE PROGRAM WITHOUT ENGINEERING ASSISTANT ..... 4-2  
Chapter 5 - INPUT DATA REQUIREMENTS ..... 5-1  
    5.1 GENERAL ..... 5-1  
    5.2 PROBLEM IDENTIFICATION..... 5-5  
    5.3 SLAB DIMESNIONS AND PROPERTIES ..... 5-5  
    5.4 STEEL BEAM DIMENSIONS AND PROPERTIES ..... 5-10  
    5.5 UNSYMMETRICAL FLANGE ..... 5-13  
    5.6 PRESTRESSED CONCRETE BEAM DIMENSIONS ..... 5-14  
    5.7 REINFORCED CONCERTE BEAM/SLAB DIMESNIONS ..... 5-21  
    5.8 SECTION LOSS/ADDITION OR BOLT HOLE DATA ..... 5-25  
Chapter 6 - OUTPUT DESCRIPTION ..... 6-1  
    6.1 GENERAL ..... 6-1  
Chapter 7 - EXAMPLE PROBLEMS ..... 7-1  
    7.1 GENERAL ..... 7-1  
    7.2 EXAMPLE PROBLEM 1 ..... 7-1  
    7.3 EXAMPLE PROBLEM 2 ..... 7-6  
    7.4 EXAMPLE PROBLEM 3 ..... 7-11  
    7.5 EXAMPLE PROBLEM 4 ..... 7-19  
    7.6 EXAMPLE PROBLEM 5 ..... 7-25  
Chapter 8 - TECHNICAL QUESTIONS AND REQUESTS ..... 8-1  
    8.1 TECHNICAL QUESTIONS..... 8-1  
    8.2 REVISION REQUESTS..... 8-1

**LIST OF FIGURES**

Figure 3.1.1 - Plastic Moment of Section..... 3-3

Figure 5.1.1 - Input Form 1..... 5-2

Figure 5.1.2 - Input Form 2..... 5-3

Figure 5.1.3 - Input Form 3..... 5-4

Figure 5.5.1 - Beam Dimensions - Box and Plank Beams ..... 5-17

Figure 5.5.2 - Beam Dimensions - Box Beam with Circular Void ..... 5-18

Figure 5.5.3 - Beam Dimensions - I-Beams ..... 5-19

Figure 5.5.4 - Beam Dimensions – Bulb-Tee Beams..... 5-20

Figure 5.5.5 - Beam Dimensions – Double-Tee (NEXT) Beams ..... 5-20

Figure 5.6.1 - Beam Dimensions – Reinforced Concrete T-beam..... 5-23

Figure 5.6.2 - Beam Dimensions – Reinforced Concrete I-beam..... 5-24

Figure 5.6.3 - Beam Dimensions – Reinforced Concrete Slab or Plank..... 5-24

Figure 5.7.1 - Section Loss/Addition and Bolt Hole Coordinates..... 5-27

Figure 7.2.1 - Section for Example 1 ..... 7-2

Figure 7.2.2 - Input for Example 1 ..... 7-3

Figure 7.2.3 - Output for Example 1 ..... 7-4

Figure 7.3.1 - Section for Example 2..... 7-7

Figure 7.3.2 - Input for Example 2 ..... 7-8

Figure 7.3.3 - Output for Example 2..... 7-9

Figure 7.4.1 - Section for Example 3..... 7-12

Figure 7.4.2 - Input for Example 3 ..... 7-13

Figure 7.4.3 - Output for Example 3 ..... 7-15

Figure 7.5.1 - Section for Example 4..... 7-20

Figure 7.5.2 - Input for Example 4 ..... 7-21

Figure 7.5.3 - Output for Example 4 ..... 7-23

Figure 7.6.1 - Section for Example 5..... 7-26

Figure 7.6.2 - Input for Example 5..... 7-27

Figure 7.6.3 - Output for Example 5..... 7-29

## Beam Section Properties

### SUMMARY OF MAY 1995 REVISIONS – VERSION 1.1

The following revisions are made to the Department's Beam Section properties program. The revised program is referred to as Version 1.1:

1. Metric dimensions for standard prestressed beams are now available.
2. Longitudinal mild steel for positive and negative moment as provided by BD-661 and BD-662 are included as output for standard prestressed beams.
3. The 15% Rule is applied to rivet or bolt holes in the tensions region for steel beam as per LRFD 6.10.1.4.
4. The Radius of Gyration of Flange plus 1/3 of Web in Compression ( $r_t$ ) for steel sections will no longer be printed since LRFD specifications require this value to be computed for specific dead load and live load reserve capacities.
5. The Area of Longitudinal Slab Reinforcement input for steel sections is now entered as  $\text{mm}^2/\text{m}$  instead of  $\text{mm}^2/\text{mm}$ . This change required an increased input field width from 6 to 8 spaces. Old input files must be changed accordingly to obtain correct results using Version 1.1.
6. Dimensions for 24" deep box beams and their metric equivalents were added to the standard prestressed concrete beam dimension tables.
7. The tapered areas of the shear keys are no longer neglected when computing section properties for adjacent prestressed concrete box beams.
8. The area of concrete in the half-depth containing the flexural tension zone is now calculated for prestressed concrete sections as described in LRFD 5.8.3.4.2. This area is required to compute the nominal shear resistance.
9. The example problems have been revised and the output is included in this revised documentation.

## Beam Section Properties

### SUMMARY OF DECEMBER 1995 REVISIONS – VERSION 1.2

The following revisions are made to the Department's Beam Section Properties program. The revised program is referred to as Version 1.2. This version was only released to the developers of the LRFD girder programs:

1. A new input item, CONSTRUCTION MODULAR RATIO, was added to BEAM DATA line. It is used to compute positive flexure composite section properties of steel beams for deck pouring staging. Input files created for previous BSP versions must be changed accordingly to run on Version 1.2.
2. The section modulus at the center of gravity of the longitudinal slab reinforcement is computed and printed for positive flexure composite steel beams.
3. The beam designation for the 1220/0840 metric prestressed concrete beam was corrected in the program's beam designation table.
4. A "divide by zero" error, that occurred while the program was computing compression flange properties for a steel beam with its compression flange completely deteriorated, was corrected.
5. The input echo for WEB THICK was corrected. Previous program versions truncated part of the input value when printing.
6. The concrete in the haunch of prestressed concrete beams is neglected for computation of composite properties. Previously, the haunch concrete was neglected for steel sections, but considered for concrete sections.
7. St. Venant's torsional constant is now computed for the basic beam section and the composite beam section (if applicable) for prestressed concrete beams.
8. The torsional constant equation for a box beam was corrected. Equation (C4.6.2.2.1-3) in the LRFD Commentary should have a 4 in the numerator instead of a 2.
9. The surface area computation for prestressed concrete box beam was revised to include the tapered shear key.
10. The example problems have NOT been revised in this revised documentation.

**SUMMARY OF APRIL 1997 REVISIONS – VERSION 1.3**

The following revisions are made to the Department's Beam Section Properties program. The revised program is referred to as Version 1.3.

1. A new variable was added for the haunch width to allow the haunch concrete to be included in composite section property calculations for prestressed concrete beams. This revision was made for internal calls to BSP from other programs. The stand-alone BSP will continue to neglect the haunch concrete's structural contribution.
2. The 15% rule for deduction of a steel section due to bolt holes, as described in LRFD 6.10.1.4, is now applied on a component-by-component basis. Previously, the 15% rule was applied to the entire section. This revision required a new input item on the SECTION LOSS/ADDITION OR HOLE DATA line for a component code to indicate the location of a hole or loss.
3. The program was revised to correctly consider section loss/addition and bolt hole effects, applying the 15% rule, for bending about the y-y axis. The moment of inertia about the y-y axis is now computed for both positive and negative flexure about the y-y axis considering loss/addition and hole effects. The lesser of these is printed in non-composite ELASTIC SECTION PROPERTIES section of the output.
4. The "T2" dimension for the 24/63 (US) and 615/1600 (SI) prestressed concrete I-beam was corrected in the program's beam designation table.
5. The example problems have been revised and the output is included in this revised documentation.

## SUMMARY OF MARCH 2015 REVISIONS – VERSION 2.0.0.0

The last standalone version of BSP (version 1.3) was released in April 1997. However, there have been several subsequent unreleased BSP versions, which addressed issues for the Department's LRFD superstructure programs (PSLRFD and STLRFD) and BAR7. BSP Version 2.0.0.0 contains the following revisions as well as the revisions listed for the unreleased versions.

1. New input fields have been added for the Slab Concrete Density and the Beam Concrete Density. These parameters are used to compute concrete modulus of elasticity and account for different slab and beam concrete weights when computing the composite section properties for prestressed concrete beams. Previously, the slab and beam concrete were assumed to have the same density. (REV012)
2. The top beam section modulus equation for a transformed composite prestressed concrete section was corrected to account for a negative distance from the composite n.a. to the top of beam and to avoid a negative section modulus. (REV013)
3. Section properties for prestressed concrete double-tee (NEXT) beams have been added. (REV016)
4. A new input parameter was added to allow the haunch concrete to be considered when computing composite section properties for prestressed concrete beam only. The haunch width is set to the beam W2 dimension. (REV017)
5. Upgraded to Intel Visual Fortran Composer XE 2013 SP1 Update 3 and Microsoft Visual Studio .NET 2012. (REV018)
6. The program has been enhanced to provide a PDF output file in addition to the text output file. The PDF file makes it easier to print and paginate the program output.
7. **The method of calling the engineering program DLL from the Engineering Assistant has been changed for compatibility with EngAsst v2.5.0.0 which uses Microsoft's .NET Framework, version 4.5. Because of this, BSP will no longer work with EngAsst v2.4.0.6 or v2.4.0.9 unless the EngAsst “Edit / Run EXE – Command Window” option is selected. BSP will no longer work with EngAsst v2.4.0.0 and earlier.**

BSP Version 1.5.0.3 (May 2009) contained the following revisions:

1. Intel Visual Fortran v10.1 conversion. (REV007)

## Beam Section Properties

2. The web thickness used when determining the shear capacity ( $W3$ ) is now set for prestressed box beams with circular voids. (REV008)
3. Variable ANC can now be used by calling programs to pass the beam concrete to slab concrete modular ratio for prestressed concrete beams when the concrete densities are different. (REV009)
4. Reformat the prestressed concrete beam section modulus output to allow larger numbers. (REV010)
5. An input check for the Slab/Beam  $f'c$  for prestressed and reinforced concrete sections was added to avoid a divide-by-zero error. (REV011)

BSP Version 1.5.0.2 (June 2006) contained the following revisions:

1. The torsional constant for Steel built-up sections and WF sections with cover plates were corrected to consider built-up sections of the beams as a single element. (REV003)
2. Added negative flexure section properties for reinforced concrete T-beams for use in AASHTO Standard Engine. (REV004)
3. Added positive and negative flexure section properties for reinforced concrete I-beams for use in AASHTO Standard Engine. (REV005)
4. Added input and output modules for reinforced concrete sections. (REV006)

BSP Version 1.5.0.1 (March 2005) contained the following revisions. Revisions 1 through 5 were required for use by BAR7.

1. BSP now computes section properties for encased steel I-beams. (BAR7 only - Rev. 1.5.01)
2. Section properties for steel beams with unsymmetrical flanges can now be computed. (BAR7 only - Rev. 1.5.02)
3. Section properties for reinforced concrete tee-beams and slabs can now be computed. (BAR7 only - Rev. 1.5.03)
4. The location of the plastic neutral axis for steel beams is now accessible to BAR7 through calls to BSP. (BAR7 only - Rev. 1.5.04)

## Beam Section Properties

5. The area of the compression flange and the area of tension flange for steel beams are now accessible to BAR7 through calls to BSP. (BAR7 only - Rev. 1.5.05)
6. Section losses\bolt holes are now considered when computing the area of tension flange for steel beams. (Rev. 1.5.06)
7. The depth of web in compression used to compute the radius of gyration of the compression flange plus one-third of the web in compression ( $r_t$ ) for a non-composite steel beam is now computed using the non-composite neutral instead of the composite neutral axis. (Rev. 1.5.07)
8. BSP source code was updated to current PENNDOT programming standards compatible with Windows XP and has been converted to a Windows DLL. (Rev. 001)
9. The beam concrete to slab concrete modular ratio is now applied to the negative flexure longitudinal stiffness parameter ( $K_g$ ). (Rev. 002)

BSP Version 1.5.0.0 (February 2004) contained the following revisions.

1. When the composite neutral axis is located in the slab for a prestressed concrete section, the program continues and computes the composite section properties. Previously, the program would not compute composite properties in such a case. (Rev. 1.4.01)
2. If the area of the longitudinal slab reinforcement is entered as zero for a steel section, the distance from the neutral axis to center of gravity of the longitudinal slab reinforcement and the section modulus at the center of gravity of the longitudinal slab reinforcement is set zero. (Rev. 1.4.02)
3. Version 1.4 Revision 2 (see Summary of Revisions – Version 1.4 on page xi) resulted in problems when computing distribution factors for the superstructure programs (PSLRFD and STLRFD). Therefore, BSP was revised to use the composite longitudinal stiffness parameter,  $K_g$ , for non-composite sections. (Rev. 1.4.03)
4. When the composite neutral axis is located in the slab, the slab concrete below the neutral axis is assumed to be cracked and is, therefore, not considered in the composite section properties. (Rev. 1.4.04)
5. A new prestressed concrete section type was added for Bulb Tee beams. Dimensions for PCEF standard bulb tees are available by entering the appropriate beam designation. (Rev. 1.4.05)

## Beam Section Properties

6. The moment of inertia calculation for the haunch in a prestressed concrete section was corrected to use the haunch width instead of the W2 beam dimension. (Rev. 1.4.06)
7. The moment of inertia about the y-axis of the slab is now included in the torsional constant for a composite prestressed concrete I-beam, Bulb-Tee and plank sections. (Rev. 1.4.07)
8. The beam designation input field for prestressed concrete beams was expanded to accommodate Bulb-Tee beam designations. (Rev. 1.4.08)
9. The default location of the shear key for adjacent prestressed concrete box beams less than 33" (840 mm) deep was changed in compliance with BC-775M. The shear key location for 12" (305 mm) plank beams remains the same. (Rev. 1.4.09)
10. The longitudinal stiffness,  $K_g$ , for composite steel beam sections is only printed once for each, the positive and negative flexure after the composite section properties. Previously, the same longitudinal stiffness was printed both after the basic beam section properties and after the composite section properties. (Rev. 1.4.10)
11. The depth of the section parameter passed to the plastic moment capacity module for steel sections is reset to the depth of the basic beam after the composite plastic moment capacity is computed. This change does not affect the standalone BSP program, but was required for repeated calls to BSP from the STLRFD program. (Rev. 1.4.11)

BSP Version 1.4 (February 2003) contained the following revisions:

1. A correction was made to plastic moment resistance calculation for built-up steel sections when the plastic n.a. goes through the vertical legs of the angles.
2. For non-composite sections (both steel and prestressed concrete), the longitudinal stiffness parameter,  $K_g$ , is set equal to the moment of inertia of basic beam instead of zero and is printed.
3. The longitudinal mild steel prestressed beam was converted to use "soft" metric bars in accordance with the revised BD-661 dual unit standard.

## Beam Section Properties

This page is intentionally left blank.

# 1

## GENERAL DESCRIPTION

### 1.1 PROGRAM IDENTIFICATION

**PROGRAM TITLE:** Beam Section Properties

**PROGRAM NAME:** BSP

**VERSION:** 2.0.0.0

**SUBSYSTEM:** Structure Design - General

**AUTHOR:** Engineering Software Section  
Bureau of Business Solutions and Services  
Pennsylvania Department of Transportation

#### ABSTRACT:

The Beam Section Properties program computes the section properties of steel **beams**, prestressed concrete beams **and reinforced concrete beam/slabs** in accordance with the **2010** LRFD Bridge Design Specifications. The properties are calculated for one section of a beam in a given run. The input consists of beam dimensions and material properties. Steel sections can be wide flange beams with or without cover plates, plate girders, or built-up sections. The slab and beam can be considered as either composite or non-composite. The steel section can be homogeneous or hybrid. Section losses, section additions, and bolts holes can also be considered. Both elastic and plastic section properties are calculated for a steel beam. Prestressed sections can be I-beams, bulb tee beams, box beams with rectangular or circular voids, **double-tee (NEXT) beams** or plank beams. Only elastic section properties are calculated for prestressed concrete beams. **Reinforced concrete sections include T-beams, I-beams, slabs and planks.** Elastic section properties are calculated for **both gross and cracked sections.** The program can accommodate either metric (SI) units or U.S. Customary units.

This page is intentionally left blank.

# 2 *PROGRAM DESCRIPTION*

## 2.1 PROGRAM DESCRIPTION

The Beam Section Properties program computes the properties of a given steel or prestressed concrete section in accordance with the 2010 AASHTO LRFD Bridge Design Specifications. The steel sections considered are wide flange beam with or without cover plates, plate girders, and built-up sections composed of angles and plates. The section can be composite or non-composite. Both the short and long-term composite actions are considered. In addition, the web plate and flange plates in a plate girder, or the wide flange beam and its cover plates can have different material strength (hybrid section) or the same material strength (homogeneous section). Section losses, section additions and bolt holes can also be considered. Prestressed concrete sections considered are I-beams, bulb tee beams, box beams with rectangular or circular voids, double-tee (NEXT) beams and planks beam. Reinforced concrete sections include T-beams, I-beams, slabs and planks.

The properties calculated are those required for Load and Resistance Factor Design (LRFD). Both the elastic and plastic section properties are calculated for a steel section, whereas only the elastic properties are calculated for prestressed concrete and reinforced concrete sections. Steel sections can also be subjected to positive flexure (top fiber in compression) or negative flexure (bottom fiber in compression). The computations can be specified in either metric (SI) units or U.S. Customary units.

The computed values are printed in line item format.

This page is intentionally left blank.

# 3

## **METHOD OF SOLUTION**

### **3.1 GENERAL**

The section properties defined in the output section are calculated using the standard formulae, which can be found in a textbook of structural engineering. The following assumptions and simplifications are used in calculating some properties.

1. In calculating the properties of a composite steel section for positive flexure, the area of reinforcement is replaced by the equal area of concrete. In addition, if the neutral axis falls in the slab, the concrete area below the neutral axis is neglected.
2. In calculating the properties of a composite steel section for negative flexure, the area of slab is neglected since concrete is assumed to carry no tensile stresses. However, the area of reinforcement is accounted for calculating the section properties.
3. In calculating the plastic moment capacity of the steel section, the location of plastic neutral axis is calculated by an iterative process rather than the formulae given in the LRFD Bridge Design Specifications. This is a more generalized method suitable for a symmetrical, unsymmetrical, homogeneous, or hybrid section. In this method, the location of the plastic neutral axis is first assumed at the mid-height of the steel section. Assuming all elements are stressed to their yield strength, forces in all elements are calculated. If there is a net axial force acting on the section, a new position of the neutral axis is assumed and the above steps are repeated until there is no net axial force acting on the section. The plastic moment is then calculated by taking the first moment of all forces about the plastic neutral axis, assuming all forces and moment arms as positive quantities. Refer to Figure 3.1.1 on page 3-3.
4. In calculating the plastic moment capacity of the steel section for positive moment, the forces in the longitudinal reinforcement are conservatively neglected.
5. The effect of a rivet or bolt hole in a steel section is only considered when the hole falls in the tension region of the section. In which case, the program applies the 15% rule for deduction of section, as specified by LRFD 6.10.1.4, on a component-by-component basis. The program first locates the neutral axis of the section, less losses and plus additions. This n.a. is used to locate the tension region. For each component (i.e. cover plate, web, flange, angle...), the program computes the gross area falling in the tension region, the total area of holes in the tensions region and total area of losses in the tension region. If the total area of holes in the tension region is greater than 15% of the area in tension less losses in tension, the area of

### Chapter 3 Method of Solution

holes in excess of 15% is subtracted when computing the section properties. The program computes a width reduction factor for each component as follows:

$$RF_{width}(comp) = \frac{[A_{holes}(comp) - 0.15(A_{tension}(comp) - A_{losses}(comp))]}{A_{holes}(comp)}$$

6. When computing section properties for adjacent prestressed concrete box beams and plank beams, the tapered areas of the shear keys are considered assuming the taper angle is 45°.
7. For built-up steel sections, the web for computing the depth of web in compression is assumed to begin at the centerline of the outermost bolt connecting the vertical legs of the angles to the web plate. The distance from the outer edge of the vertical legs to the centerline of the first bolt hole is assumed to be 1.5" (U.S.) or 38 mm (SI).
8. The moment of inertia about the y-y axis for steel sections is computed for both positive and negative flexure about the y-y axis considering loss/addition and hole effects. The lesser of these is printed.
9. The unit weight of concrete for a beam is assumed to be 150 lbs/ft<sup>3</sup> or 2400 kg/m<sup>3</sup>. For prestressed concrete beams, separate input fields for the unit weight of the beam and the unit weight of the slab concrete are provided to account for the use of lightweight aggregate when computing the concrete modulus of elasticity.
10. The area of longitudinal mild steel for prestressed concrete beams is per the current BD-661 and BD-662 Standards. The middle bars in the PA I-beam are neglected.
11. The area of longitudinal mild steel for prestressed concrete beams in negative flexure does not include the reinforcement in the slab.
12. St. Venant's Torsional constant is computed using LRFD equations C4.6.2.2.1-1 through C4.6.2.2.1-3. The torsional constant for a composite prestressed concrete box section is computed assuming a box section with a top slab thickness equal to sum the basic beam top slab thickness plus the effective slab thickness. The slab projections and haunch are typically neglected.
13. The haunch concrete is typically neglected for all section property computations. However, the haunch depth is included in all depth and distance computations. For prestressed concrete beam, there is an option to consider the haunch concrete.
14. The surface area of the basic beam for a prestressed concrete section is computed using the entire outside perimeter of the basic beam section. The tapered portion of the shear key is considered when applicable.

Chapter 3 Method of Solution

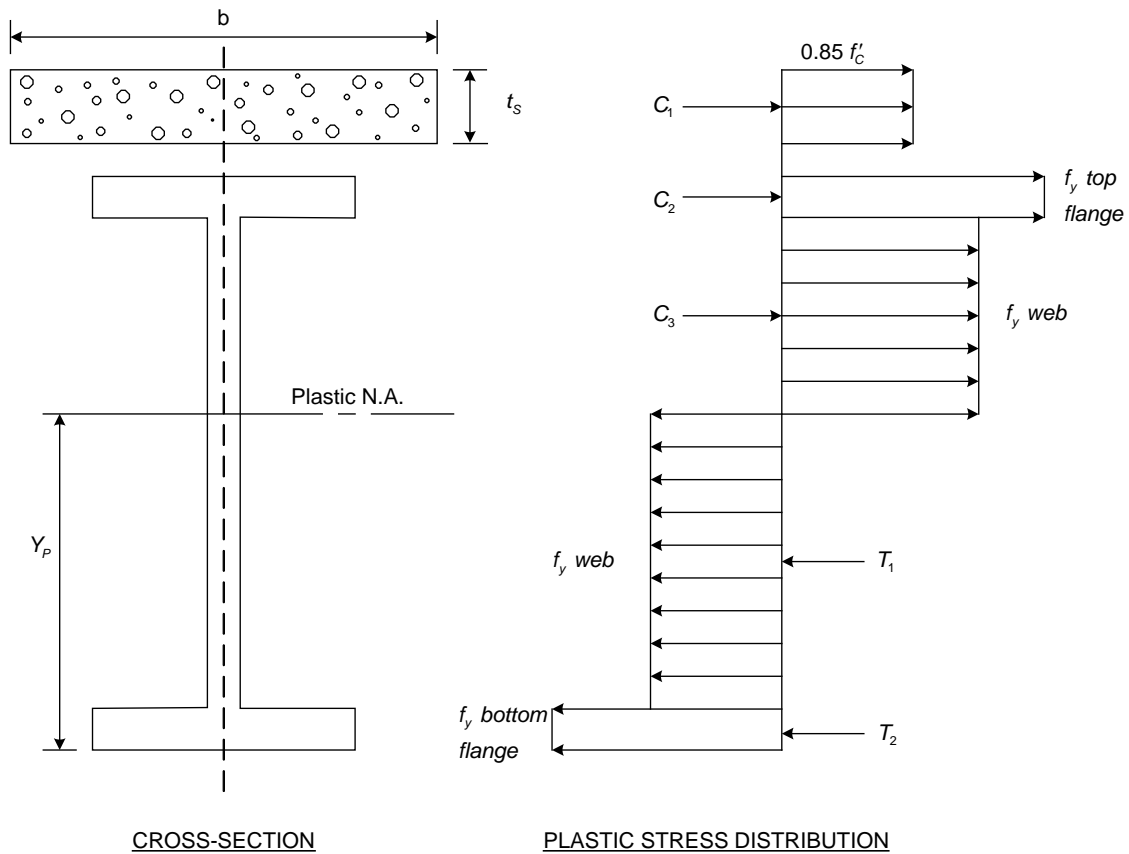

$$C_1 = 0.85 f'_c b t_s$$

$$C_2 = (\text{Area of top flange}) (f_y \text{ top flange})$$

$$C_3 = (\text{Area of web above n.a.}) (f_y \text{ web})$$

$$T_1 = (\text{Area of web below n.a.}) (f_y \text{ web})$$

$$T_2 = (\text{Area of bottom flange}) (f_y \text{ bottom flange})$$

$$Y_P = \text{distance of plastic n.a. from bottom}$$

$$Y_{C_1} = \text{distance of } C_1 \text{ from plastic n.a.}$$

$$Y_{C_2} = \text{distance of } C_2 \text{ from plastic n.a.}$$

$$Y_{C_3} = \text{distance of } C_3 \text{ from plastic n.a.}$$

$$Y_{T_1} = \text{distance of } T_1 \text{ from plastic n.a.}$$

$$Y_{T_2} = \text{distance of } T_2 \text{ from plastic n.a.}$$

$$M = C_1 Y_{C_1} + C_2 Y_{C_2} + C_3 Y_{C_3} + T_1 Y_{T_1} + T_2 Y_{T_2}$$

Figure 3.1.1 - Plastic Moment of Section

This page is intentionally left blank.

# 4 **GETTING STARTED**

## 4.1 **INSTALLATION**

This program is delivered via download from the Department's website. Once payment has been received by PennDOT, you will receive a confirmation e-mail with instructions on how to download the software. The download file is a self-extracting installation file for the licensed PennDOT engineering software. The engineering program runs as a 32-bit application and is supported on Windows Vista, Windows 7 (32 and 64 bit versions), and Windows 8 (32 and 64 bit versions) operating systems.

Your license number, license key and registered company name, found in the e-mail received from the Department, are required to be entered when installing the program and must be entered exactly as shown in the e-mail. The license number, license key and registered company name will also be needed when requesting future versions of the program (i.e., enhancements, modifications, or error corrections), and requesting program support. A backup copy of the program download and e-mail instructions should be made and used for future installations. You may want to print the software license agreement, record the license number, license key and registered company name and keep it in a safe place.

To install the program, follow the installation instructions provided with the original e-mail from the Department.

The following files will be installed in the program destination folder, which defaults to "C:\Program Files\PennDOT\ABUT5 v<version\_number>" or "C:\Program Files (x86)\PennDOT\ABUT5 v<version number>" for 64-bit operating systems:

- |                                |   |  |
|--------------------------------|---|--|
| 1. BSP.exe, BSP_DLL.dll        | – | Executable program and Dynamic Link Library.                   |
| 2. BSP Users Manual.pdf        | – | Program User's Manual (PDF Format).                            |
| 3. BSPRevisionRequestForm.dotx | – | Revision Request form (MS WORD template).                      |
| 4. GettingStarted.pdf          | – | A document describing installation and running of the program. |
| 5. LicenseAgreement.pdf        | – | The program license agreement.                                 |
| 6. MSVCR71.dll                 | – | Runtime Dynamic Link Library.                                  |

## Chapter 4 Getting Started

The program example problem files (ex\*.dat) will be installed in the program example folder, which defaults to "C:\PennDOT\ABUT5 v<version\_number> Examples\". Users must have write access to this folder in order to run the input files from this folder.

The program example problem files (ex\*.dat) will be installed in the program example folder, which defaults to "C:\PennDOT\BSP v<version\_number> Examples\". Users must have write access to this folder in order to run the input files from this folder.

### 4.2 PREPARING INPUT

The program requires an ASCII input file. The input file consists of a series of data lines. Each data line consists of a number of fixed length data fields. A decimal point must be included for any numerical data. Otherwise, the data will be read as an integer. Chapter 5 of the User's Manual includes descriptions of the input and input forms to facilitate data preparation. The input can be created using Engineering Assistant, described below, or any text editor.

### 4.3 ENGINEERING ASSISTANT

The Engineering Assistant (EngAsst) is a Windows application developed by the Pennsylvania Department of Transportation (PENNDOT) to provide a graphical user interface (GUI) for PENNDOT's engineering programs. The data for the input to the engineering program is presented in a user-friendly format, reflecting the implied structure of the data, showing each record type on a separate tab page in the display and showing each field on each record with a defining label.

With EngAsst the user can create a new input file, modify an existing input file, import input files, run the associated engineering program and view the output in a Windows environment. The help and documentation are provided, including text descriptions of each field, relevant images, and extended help text at both the record/tab level and the field level. The entire Engineering Program User's Manual is also accessible within EngAsst.

EngAsst is not included with this software. It requires a separate license that can be obtained through the Department's standard engineering software licensing procedures. Order forms can be obtained from the software support website at <http://penndot.engrprograms.com>.

### 4.4 RUNNING THE PROGRAM WITHOUT ENGINEERING ASSISTANT

BSP is a FORTRAN console application program. It may be run from a command window, by double-clicking on the program icon from Windows Explorer, by selecting the shortcut from the Start menu under Programs\PennDOT, or by double-clicking the shortcut icon on the desktop. To run the program in a command window, the user must specify the directory in which the program has been installed or change to the directory.

## Chapter 4 Getting Started

The program will first prompt for an input file name, and the user should then enter the appropriate input file name. The input file must be created before running the program. The program will then prompt for whether the output should be reviewed on the screen. The user should enter “Y” if the output is to be reviewed on the screen after execution or “N” if the output is not to be reviewed on the screen. The program will then prompt for the name of the output file in which the output is to be stored, and the user should then enter the desired output file name. If a file with the specified output file name already exists, the program gives the option of overwriting the existing file or entering a new output file output file name. If no output file name is entered, a default output file will be used. The program will then execute.

To cancel the program during execution, press <Ctrl C> or <Ctrl Break>.

When the program completes execution, the user is prompted to “Press <ENTER> to exit program.” This allows the user to view the last messages written to the screen when the program was started by double-clicking on the program icon from Windows Explorer.

The user can view the output file from within EngAsst or using a text editor.

This page is intentionally left blank.

# 5

## ***INPUT DATA REQUIREMENTS***

### **5.1 GENERAL**

Input Forms (see Figure 5.1.1 on page 5-2, Figure 5.1.2 on page 5-3 and Figure 5.1.3 on page 5-4) have been prepared to facilitate data preparation for execution of this program.

The program accepts input values in either U.S. Customary or metric (SI) units. All values must be entered in one type of units only.

The input forms have been designed to accept values in both U.S. Customary and metric (SI) units so the implied decimal places are not used in the formats. Thus, the decimal point must be entered for each input item. If a decimal point is not entered, the input value will be read as a whole number.

The following sections describe each data item and explain which data items must be entered for the solution of a particular problem.

BSP  
BEAM SECTION PROPERTIES

PENNSYLVANIA DEPARTMENT OF TRANSPORTATION  
BUREAU OF INFORMATION SYSTEMS

PROJECT IDENTIFICATION	
1	
2	
#	
#	
#	

SLAB DIMENSIONS AND PROPERTIES

UNITS	EFFECTIVE		SLAB F'c	MODULAR RATIO	CONSTRUCTION MODULAR RATIO	P/S CONC BEAM or RC SLAB DATA			FLEXURE OUTPUT	# OF SECT LOSS/ADD	NEGLECT CMR	SLAB CONCRETE UNIT WEIGHT FOR E <sub>c</sub>	BEAM CONCRETE UNIT WEIGHT FOR E <sub>c</sub>	INCL HAUNCH				
	WIDTH	THICK				HAUNCH	AREA P/S STR or TOP REINF	C.G. P/S STR or TOP REINF							BEAM F'c or Fy REINF			
1	2	3	9	14	19	25	27	29	37	43	49	50	51	53	54	60	66	67

STEEL BEAM DIMENSIONS AND PROPERTIES

SECT TYPE	WF BEAM M OF I OR ANGLE VERT LEG	WF BEAM AREA OR ANGLE HORZ LEG	FLANGE OR ANGLE THICK	FLANGE WIDTH	WF BEAM OR WEB PLATE DEPTH	WEB THICK	TOP PLATE		BOTTOM PLATE		Fy WEB	Fy TOP	Fy BOT	
							WIDTH	THICK	WIDTH	THICK				
1	2	10	16	22	28	34	40	45	51	56	62	63	69	75

UNSYMMETRICAL  
FLANGE

CG TOP	CG BOTTOM
1	7

PREPARED BY ..... DATE ...../...../..... SHEET ..... OF .....

Figure 5.1.1 - Input Form 1

PENNSYLVANIA DEPARTMENT OF TRANSPORTATION  
BUREAU OF INFORMATION SYSTEMS

**BSP**  
**BEAM SECTION PROPERTIES**

**P/S CONCRETE BEAM DIMENSIONS**

TYPE	COMP	DESIG or D	W1	W2	W3	T1	T2	B1	B2	B3	B4	D1	D2	X1	X2
1	2	3	11	17	23	28	33	38	43	48	53	58	63	68	73

**REINFORCED CONCRETE BEAM DIMENSIONS AND PROPERTIES**

TYPE	DEPTH	WEARING SURFACE THICKNESS	TOP FLANGE WIDTH	TOP FLANGE THICKNESS	TOP FLANGE FILLET HORZ	TOP FLANGE FILLET VERT	TOP WEB THICKNESS	BOTTOM WEB THICKNESS	AREA BOTTOM REINF	DISTANCE TO BOTTOM REINF	BOTTOM FLANGE WIDTH	BOTTOM FLANGE THICKNESS	BOTTOM FLANGE FILLET HORZ	BOTTOM FLANGE FILLET VERT
1	2	8	13	19	25	30	35	41	47	53	59	65	71	76

Figure 5.1.2 - Input Form 2



## Chapter 5 Input Data Requirements

### 5.2 PROBLEM IDENTIFICATION

Lines are provided to enter user comments for problem identification. The first column of each line must contain an asterisk (\*) to indicate that this is a user comment. Any number of lines of data may be supplied within the input data, but only the first three lines will be printed on the output.

### 5.3 SLAB DIMENSIONS AND PROPERTIES

This line describes the data related to the entire beam. Each input item is described below.

#### UNITS

Enter "M" if all input values and computed values are to be in metric (SI) units. The default is "M".

Enter "U" if all input values and computed values are to be in U.S. Customary units.

#### MATERIAL

Enter "S" if the dimensions are entered for a steel beam.

Enter "P" if the dimensions are entered for a prestressed concrete beam.

Enter "R" if the dimensions are entered for a reinforced concrete beam.

#### EFFECTIVE SLAB WIDTH

For a prestressed concrete beam or a steel beam, enter the effective width of the composite slab - in or mm.

For a reinforced concrete beam (I-beam, T-beam or plank beam), enter the effective width of the top flange - in or mm.

Leave blank for a reinforced concrete slab (RC Type "S"). The section effective width is assumed to be 1 ft (12 in) or 1 m (1000 mm).

#### EFFECTIVE SLAB THICK

If the section is composite, enter the effective thickness of composite slab – inches or mm.

#### EFFECTIVE SLAB HAUNCH

The distance from the top of the beam (do not include cover plate) to the bottom of the slab – inches or mm. This value is negative if the bottom of the slab is below the top of the beam.

## Chapter 5 Input Data Requirements

### SLAB F'c

The compressive strength of concrete – psi or MPa. This must be entered for a composite section.

### MODULAR RATIO

For a prestressed concrete beam, enter the ratio of the modulus of elasticity of the prestressing steel to that of the beam concrete. The modulus of elasticity of the beam should correspond to the F'c which will be entered later.

For a steel beam, enter the ratio of the modulus of elasticity of the beam steel to that of the slab concrete. The modulus of elasticity of the slab should correspond to the F'c entered above.

For a reinforced concrete beam or slab, enter the ratio of the modulus of elasticity of the reinforcement steel to that of the beam or slab concrete. The modulus of elasticity of the concrete should correspond to the F'c entered above.

### CONSTRUCTION MODULAR RATIO

For a steel beam, enter the ratio of the modulus of elasticity of beam to that of the slab during construction. A typical value is the short-term modular ratio divided by 0.7. Leave blank if composite construction section properties are not desired.

Leave blank for a prestressed concrete beam or a reinforced concrete beam.

### PRESTRESSED CONCRETE BEAM or RC SLAB DATA

The following three input items have different definitions depending on the beam type.

#### AREA P/S STRANDS or LONGITUDINAL SLAB REINF

For a prestressed concrete beam, enter the total area of all prestressing strands – in<sup>2</sup> or mm<sup>2</sup>.

For a steel beam, enter the area of longitudinal reinforcement per unit width of slab (foot or m) that is to be included in calculating the negative flexure section properties – in<sup>2</sup>/ft or mm<sup>2</sup>/m.

For a reinforced concrete beam or slab, enter the total area of the top longitudinal reinforcement in the effective top flange or slab width - in<sup>2</sup> or mm<sup>2</sup>. For a reinforced concrete slab, the effective section width is assumed to be 1 ft or 1 m.

## Chapter 5 Input Data Requirements

### C.G. P/S STRANDS or LONGITUDINAL SLAB REINFF

For a prestressed concrete beam, enter the distance measured from the bottom of the beam to the c.g. of the prestressing strands – inches or mm.

For a steel beam, enter the distance measured from the top of the slab to the c.g. of the longitudinal slab reinforcement – inches or mm. Use the effective slab thickness, i.e., the constructed thickness less the integral wearing surface, to calculate this distance.

For a reinforced concrete beam/slab, enter the distance measured from the top of the section to the c.g. of the top longitudinal reinforcement - inches or mm. Use the effective top flange/slab thickness, i.e., the constructed thickness less the integral wearing surface, to calculate this distance.

### F'c BEAM or Fy REINF

For a prestressed concrete beam, enter the compressive strength of the beam concrete – psi or MPa. This value must be entered for a composite section.

For a steel beam or a reinforced concrete beam/slab, enter the yield strength of slab reinforcement – psi or MPa.

### FLEXURE

Enter “P” if the section is in positive flexure (top fiber of section is in compression).

Enter “N” if the section is in negative flexure (top fiber of section is in tension).

Leave blank to compute section properties for both positive and negative flexure. Leave blank for a prestressed concrete beam.

### OUTPUT

Enter one of the following codes to obtain a group of section properties for a given run.

“0” – compute and print all section properties

“1” – compute and print the moment of inertia about x-x axis

“2” – compute and print only elastic section properties

“3” – compute and print only plastic section properties

Leave blank for a prestressed concrete beam or a reinforced concrete beam/slab.

## Chapter 5 Input Data Requirements

### NUMBER OF SECTION LOSSES/ADDITIONS

For a steel beam, enter the total number of section losses, section additions and bolt holes to be defined.

Leave blank for a prestressed concrete beam or a reinforced concrete beam/slab.

### NEGLECT COMPR REINF

For a reinforced concrete beam, enter "Y" to neglect compression reinforcement when calculating section properties or "N" to consider compression reinforcement. The default is "N".

Leave blank for a steel beam or a concrete prestressed beam.

### SLAB CONCRETE DENSITY

For prestressed concrete beams, enter the concrete unit weight/density of the slab concrete for computing the modulus of elasticity ( $E_{c(\text{slab})}$ ) - lb/ft<sup>3</sup> or kg/m<sup>3</sup>.

The modulus of elasticity is used to compute the modular ratio for computing the section properties. The default is 145 lb/ft<sup>3</sup> (2320 kg/m<sup>3</sup>).

Leave blank for a steel beam or a reinforced concrete beam/slab.

### BEAM CONCRETE DENSITY

For prestressed concrete beams, enter the beam concrete unit weight/density for computing the beam modulus of elasticity ( $E_{c(\text{beam})}$ ) - lb/ft<sup>3</sup> or kg/m<sup>3</sup>.

The modulus of elasticity is used to compute the modular ratio for computing the section properties. The default is 145 lb/ft<sup>3</sup> (2320 kg/m<sup>3</sup>).

Leave blank for a steel beam or a reinforced concrete beam/slab.

### UNSYMMETRICAL FLANGE

For steel plate girders or a WF beam with cover plates, enter "Y" if the UNSYMMETRICAL FLANGE data line is used to define flange or cover plate deterioration resulting in the top and/or bottom flange/cover plate being unsymmetrical about the centerline of the web.

Enter "N" or leave blank if the UNSYMMETRICAL FLANGE data line is not used.

Leave blank for a prestressed concrete beam or a reinforced concrete beam/slab.

## Chapter 5 Input Data Requirements

### INCLUDE HAUNCH

For a prestressed concrete girder, enter "Y" to consider the haunch concrete in the composite section property calculations. The haunch width is set the beam W2 dimension.

Enter "N" or leave blank if the haunch concrete is not considered for the composite section property calculations. The haunch depth is still used to locate the bottom of the slab.

Leave blank for a steel beam or a reinforced concrete beam/slab.

## Chapter 5 Input Data Requirements

### 5.4 STEEL BEAM DIMENSIONS AND PROPERTIES

If an "S" is entered for MATERIAL in the SLAB DIMENSIONS AND PROPERTIES line, enter this line to define the dimensions and material properties of the steel beam.

#### SECT TYPE

Enter one of the following codes to define the type of section.

Enter "W" if the section is a wide flange beam.

Enter "B" if the section is a built-up section made up of web plate, angles and flange plates.

Enter "P" if the section is a welded plate girder.

#### WF BEAM M OF I OR ANGLE VERT LEG

If "W" is entered for SECT TYPE, enter the moment of inertia of the wide flange beam – in<sup>4</sup> or 10<sup>9</sup> mm<sup>4</sup>. The entered value is multiplied by 10<sup>9</sup> to obtain the moment of inertia in mm<sup>4</sup> in metric (SI) units.

If "B" is entered for SECT TYPE, enter the length of the vertical leg of the angle – inches or mm.

If "P" is entered for SECT TYPE, leave this blank.

#### WF BEAM AREA OR ANGLE HORZ LEG

If "W" is entered for SECT TYPE, enter the area of the wide flange beam – in<sup>2</sup> or 10<sup>3</sup> mm<sup>2</sup>. The entered value is multiplied by 10<sup>3</sup> to obtain the area in mm<sup>2</sup> in metric (SI) units.

If "B" is entered for SECT TYPE, enter the length of the horizontal leg of the angle – inches or mm.

If "P" is entered for SECT TYPE, leave this blank.

#### FLANGE OR ANGLE THICK

If "W" is entered for SECT TYPE, enter the flange thickness of the wide flange beam – inches or mm.

If "B" is entered for SECT TYPE, enter the thickness of the angle – inches or mm.

If "P" is entered for SECT TYPE, leave this blank.

## Chapter 5 Input Data Requirements

### FLANGE WIDTH

If “W” is entered for SECT TYPE, enter the flange width of the wide flange beam – inches or mm.

If “B” or “P” is entered for SECT TYPE, leave this blank.

### WF BEAM OR WEB PLATE DEPTH

If “W” is entered for SECT TYPE, enter the depth of the wide flange beam – inches or mm.

If “B” or “P” is entered for SET TYPE, enter the depth of the web plate – inches or mm.

### WEB THICK

The thickness of the web – inches or mm. This must be entered for all SECT TYPES.

### TOP PLATE WIDTH

If “W” is entered for SECT TYPE, enter the width of the top cover plate – inches or mm. Leave blank if there is no cover plate.

If “B” is entered for SECT TYPE, enter the width of the flange plate – inches or mm. Leave blank if there is no flange plate.

If “P” is entered for SECT TYPE, enter the width of top flange – inches or mm.

### TOP PLATE THICK

If “W” is entered for SECT TYPE, enter the thickness of the top cover plate – inches or mm. Leave blank if there is no cover plate.

If “B” is entered for SECT TYPE, enter the thickness of the top flange plate – inches or mm. Leave blank if there is no flange plate.

If “P” is entered for SECT TYPE, enter the thickness of the top flange, inches or mm.

### BOT PLATE WIDTH

If “W” is entered for SECT TYPE, enter the width of the bottom cover plate – inches or mm. Leave blank if there is no cover plate.

If “B” is entered for SECT TYPE, enter the width of the bottom flange plate – inches or mm. Leave blank if there is no flange plate.

If “P” is entered for SECT TYPE, enter the width of bottom flange – inches or mm.

## Chapter 5 Input Data Requirements

### BOT PLATE THICK

If “W” is entered for SECT TYPE, enter the thickness of the bottom cover plate – inches or mm. Leave blank if there is no cover plate.

If “B” is entered for SECT TYPE, enter the thickness of the bottom flange plate – inches or mm. Leave blank if there is no flange plate.

If “P” is entered for SECT TYPE, enter the thickness of the bottom flange – inches or mm.

### COMPOSITE

Enter ‘Y’ if the section is composite.

Enter “N” if the section is non-composite.

### Fy WEB

For a homogeneous section, enter the yield strength of the entire section – psi or MPa.

For a hybrid section, enter the yield strength of the web – psi or MPa.

### Fy TOP

For a homogeneous section, leave this blank.

For a hybrid section, enter the yield strength of the top flange or cover plate – psi or MPa.

### Fy BOT

For a homogeneous section, leave this blank.

For a hybrid section, enter the yield strength of the bottom flange or cover plate – psi or MPa.

**5.5 UNSYMMETRICAL FLANGE**

For a steel plate girder with unsymmetrical flange plates or a WF beam with unsymmetrical cover plates, enter the horizontal distances from the c.g. of the plate or cover plate to the centerline of the web. This data can be used to simulate section loss or deterioration at the end of the flange or cover plate.

The UNSYMMETRICAL FLANGE data line should only be entered if “Y” is entered for the UNSYMMETRICAL FLANGE field of the SLAB DIMENSION AND PROPERTIES data line.

NOTE: Deteriorated wide flange sections with deterioration in the flange can be described either with negative cover plate thickness or by entering as a plate girder with unsymmetrical CG depending on the location and type of deterioration. If a negative cover plate thickness is entered for a wide flange section and the cover plate width is not entered, the program will assume that the section loss is over the entire width of the flange. Currently, the program does not have any provision to enter deterioration in the web. However, if the user enters a reduced WEB THICK to account for deterioration in the web, then the user must also account for this loss in the input of WF BEAM M OF I and WF BEAM AREA.

**UNSYMMETRICAL CG TOP**

For a section unsymmetrical about the vertical (Y-Y) axis, enter the distance of the center of gravity of the top plate or cover plate from the vertical centerline of the web – inches or mm. The distance is positive to the right and negative to the left of the web centerline.

**UNSYMMETRICAL CG BOTTOM**

For a section unsymmetrical about the vertical (Y-Y) axis, enter the distance of the center of gravity of the bottom plate or cover plate from the vertical centerline of the web – inches or mm. The distance is positive to the right and negative to the left of the web centerline.

## Chapter 5 Input Data Requirements

### 5.6 PRESTRESSED CONCRETE BEAM DIMENSIONS

Symbols used on the input form and in Figure 5.5.1, Figure 5.5.2, Figure 5.5.3, Figure 5.5.4 and Figure 5.5.5 on pages 5-17, 5-18, 5-19 and 5-20 are the same. For I-beams, box beam with rectangular voids, and plank beams, either enter all beam dimensions or enter the beam designation to use dimensions for standard beams. If the beam designation is entered, individual standard dimensions can be overridden by entering a value for the desired dimension. For box beams with circular voids, enter all dimensions except W3, T1, and T2. B4 is not used for box beam with a single circular void. **For Double-tee (NEXT) beams, enter all dimensions except T1, D1, D2, X1 and X2.** All dimensions are entered in inches (U.S.) or mm (SI).

#### TYPE

Enter "B" for a Box beam with a rectangular void.

Enter "C" for a Box beam with circular voids.

Enter "I" for an I-beam.

Enter "T" for a Bulb tee beam.

**Enter "D" for a Double-tee (NEXT) beam.**

Enter "P" for a Plank beam.

#### COMP

Enter "Y" if the beam is composite.

Enter "N" or leave blank if the beam is non-composite.

Note: For a composite section, the EFFECTIVE SLAB THICK and EFFECTIVE SLAB HAUNCH must be entered.

#### DESIG or D

Enter beam depth D if all beam dimensions are to be entered.

Enter the Standard Beam Designation (e.g., "2654 for a 26/54 AASHTO type I-beam or "06651375" for an equivalent metric beam) if the beam dimensions are to be completed by the program. Beam designations must be entered starting from the leftmost column of the field.

The U.S. Customary unit beam designations for Bulb-tee beams must include the decimal point and only the significant digits to right of the decimal point. For example, the 33/55.25 beam should be entered as "3355.25" and the 33/55.5 beam should be entered as "3355.5" (Note: "3355.50" is not a valid entry).

## Chapter 5 Input Data Requirements

The dimensions for the following beam designations for U.S. Customary Units listed in BD-652 are stored in the program:

PA I-beams: 18/30, 20/33, 18/33, 20/30, 24/33, 26/33, 18/36, 20/36, 24/36, 26/36, 20/39, 24/42, 24/45, 24/48, 24/51, 24/54, 24/60, 26/60, 24/63, 26/63.

AASHTO Type I-beams: 26/54, 28/63, 28/66, 28/72, 28/78, 28/84, 28/90, 28/96.

Bulb Tee Beams: 33/29.25, 33/29.5, 33/31.25, 33/31.5, 33/37.25, 33/37.5, 33/39.25, 33/39.5, 33/45.25, 33/45.5, 33/47.25, 33/47.5, 33/53.25, 33/53.5, 33/55.25, 33/55.5, 33/61.25, 33/61.5, 33/63.25, 33/63.5, 33/69.25, 33/69.5, 33/71.25, 33/71.5, 33/77.25, 33/77.5, 33/79.25, 33/79.5, 33/85.25, 33/85.5, 33/87.25, 33/87.5, 33/93.25, 33/93.5, 33/95.25, 33/95.5.

Plank Beams: 36/12, 48/12.

Box Beams: 36/17, 36/21, 36/24, 36/27, 36/30, 36/33, 36/36, 36/39, 36/42, 36/45, 36/48, 36/54, 36/60, 36/66, 48/17, 48/21, 48/24, 48/27, 48/30, 48/33, 48/36, 48/39, 48/42, 48/45, 48/48, 48/54, 48/60, 48/66.

The dimensions for the following beam designation for SI Units listed in BD-652 are stored in the program:

PA I-beams: 0455/0760, 0505/0760, 0455/0835, 0505/0835, 0610/0835, 0660/0835, 0455/0915, 0505/0915, 0610/0915, 0660/0915, 0505/0995, 0615/0995, 0615/1065, 0615/1145, 0615/1220, 0615/1295, 0615/1370, 0615/1370, 0615/1520, 0665/1520, 0615/1600, 0665/1600.

AASHTO Type I-beams: 0655/1375, 0715/1600, 0715/1675, 0715/1825, 0715/1980, 0715/2130, 0715/2285, 0715/2435.

## Chapter 5 Input Data Requirements

Bulb Tee Beams: 0845/0745, 0845/0750, 0845/0795, 0845/0800, 0845/0950, 0845/0955, 0845/1000, 0845/1005, 0845/1155, 0845/1160, 0845/1205, 0845/1210, 0845/1355, 0845/1360, 0845/1405, 0845/1410, 0845/1560, 0845/1565, 0845/1610, 0845/1615, 0845/1765, 0845/1770, 0845/1815, 0845/1820, 0845/1965, 0845/1970, 0845/2015, 0845/2020, 0845/2170, 0845/2175, 0845/2220, 0845/2225, 0845/2370, 0845/2375, 0845/2420, 0845/2425.

Plank Beams: 0915/0305, 1220/0305.

Box Beams: 0915/0430, 0915/0535, 0915/0610, 0915/0685, 0915/0760, 0915/0840, 0915/0915, 0915/0990, 0915/1065, 0915/1145, 0915/1220, 0915/1370, 0915/1525, 0915/1675, 1220/0430, 1220/0535, 1220/0610, 1220/0685, 1220/0760, 1220/0840, 1220/0915, 1220/0990, 1220/1065, 1220/1145, 1220/1220, 1220/1370, 1220/1525, 1220/1675.

W1, W2, W3, T1, T2, B1, B2, B3, B4, D1, D2, X1, X2

Refer to [Figure 5.5.1](#), [Figure 5.5.2](#), [Figure 5.5.3](#), [Figure 5.5.4](#) and [Figure 5.5.5](#) on pages 5-17, 5-18, 5-19, and 5-20 for beam dimensions for each beam type.

Note: **W1** must be left blank if the program is to complete beam dimensions using the Beam Designation entered above. If any other dimensions are entered when using the Beam Designation option, they will override the standard dimension.

Box beams are classified as adjacent only if the EFFECTIVE SLAB WIDTH is equal to W1. Therefore, beam dimensions (specifically the shear key dimensions) must be entered for any adjacent box fascia beam with a parapet overhang.

For Double-tee (NEXT) beams, the chamfer dimension (B3) defaults to 0.75" (19 mm) and the top flange edge draft dimension (B4) defaults to 0.25" (6 mm) if left blank.



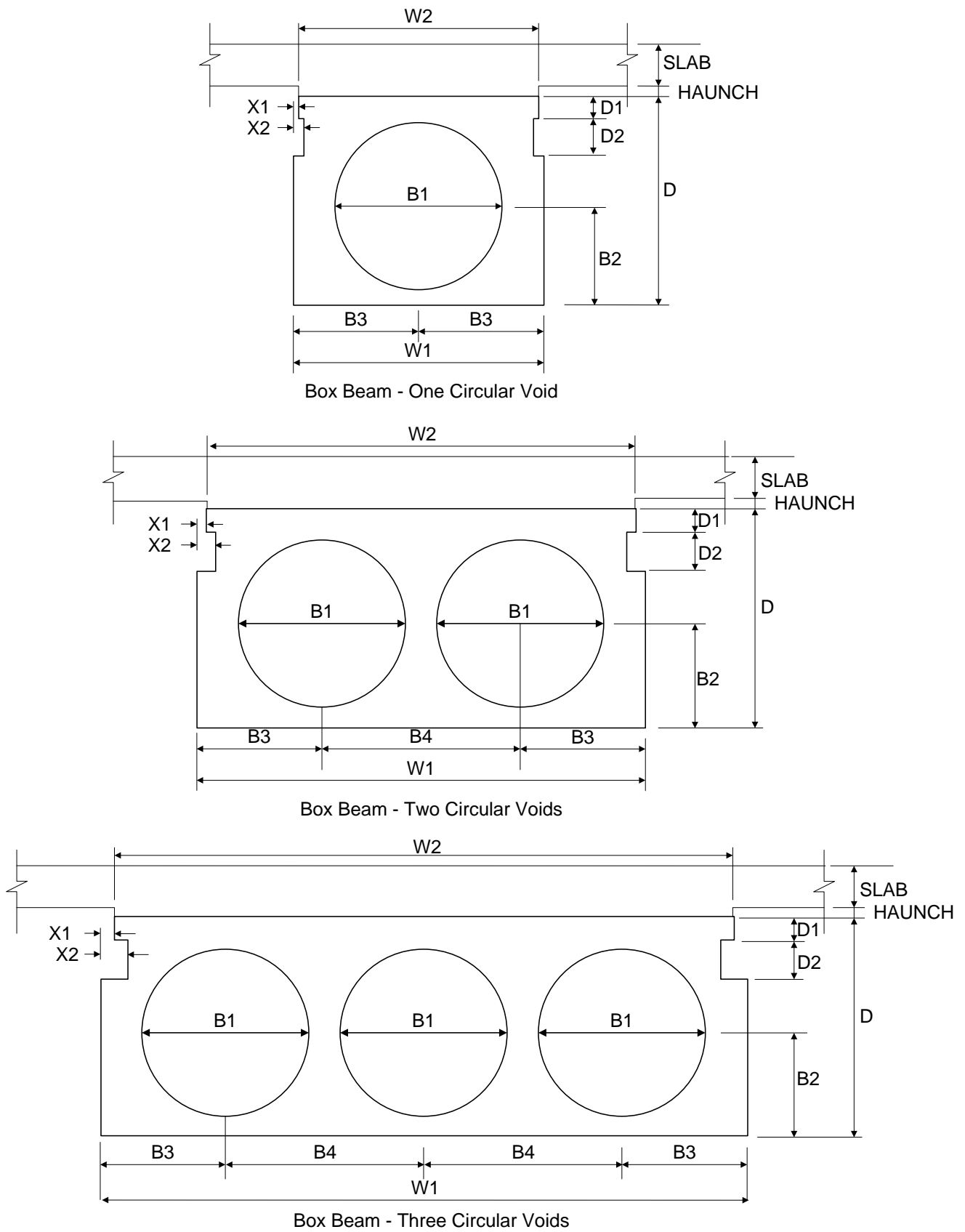

Figure 5.5.2 - Beam Dimensions - Box Beam with Circular Void

Chapter 5 Input Data Requirements

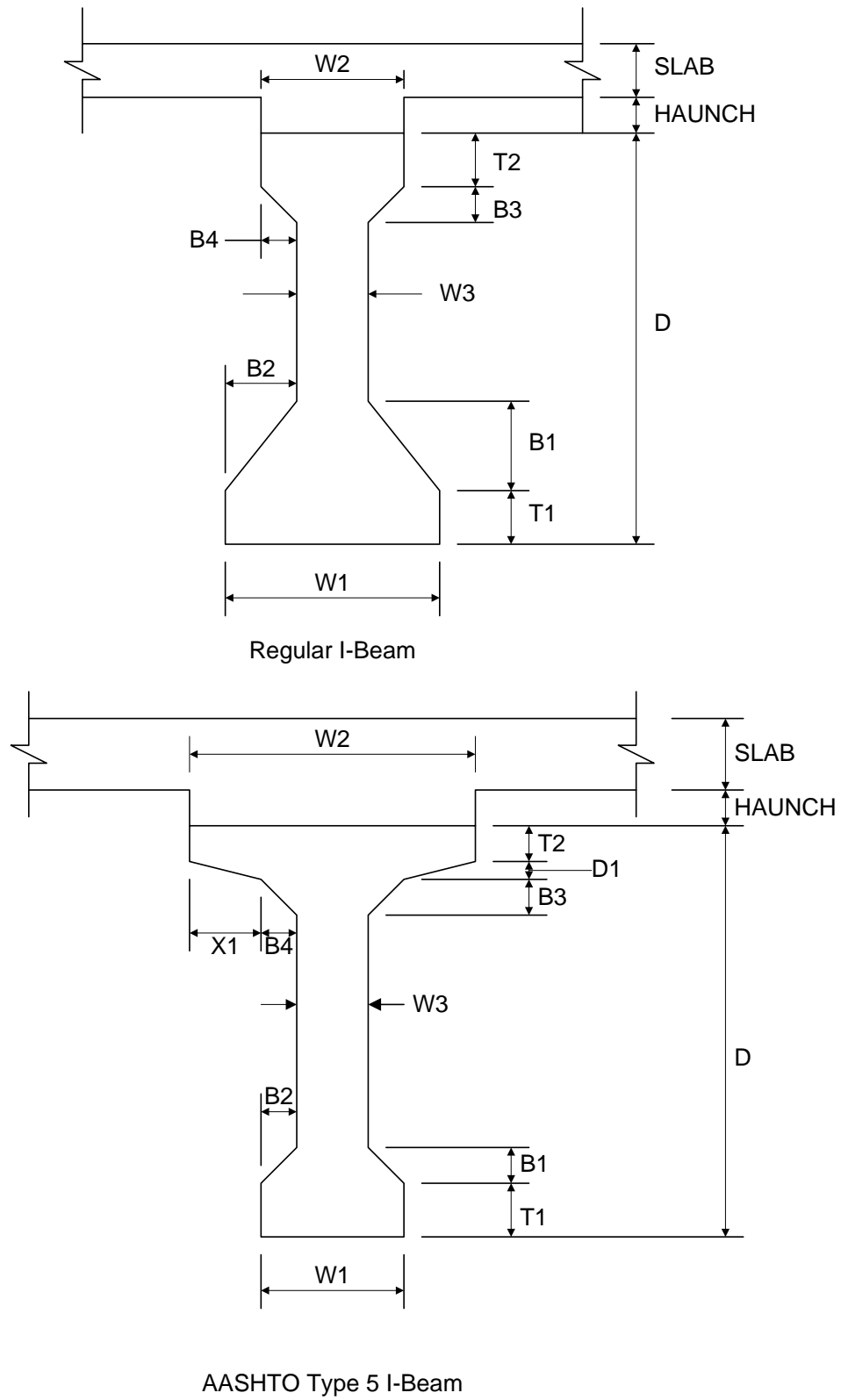

Figure 5.5.3 - Beam Dimensions - I-Beams

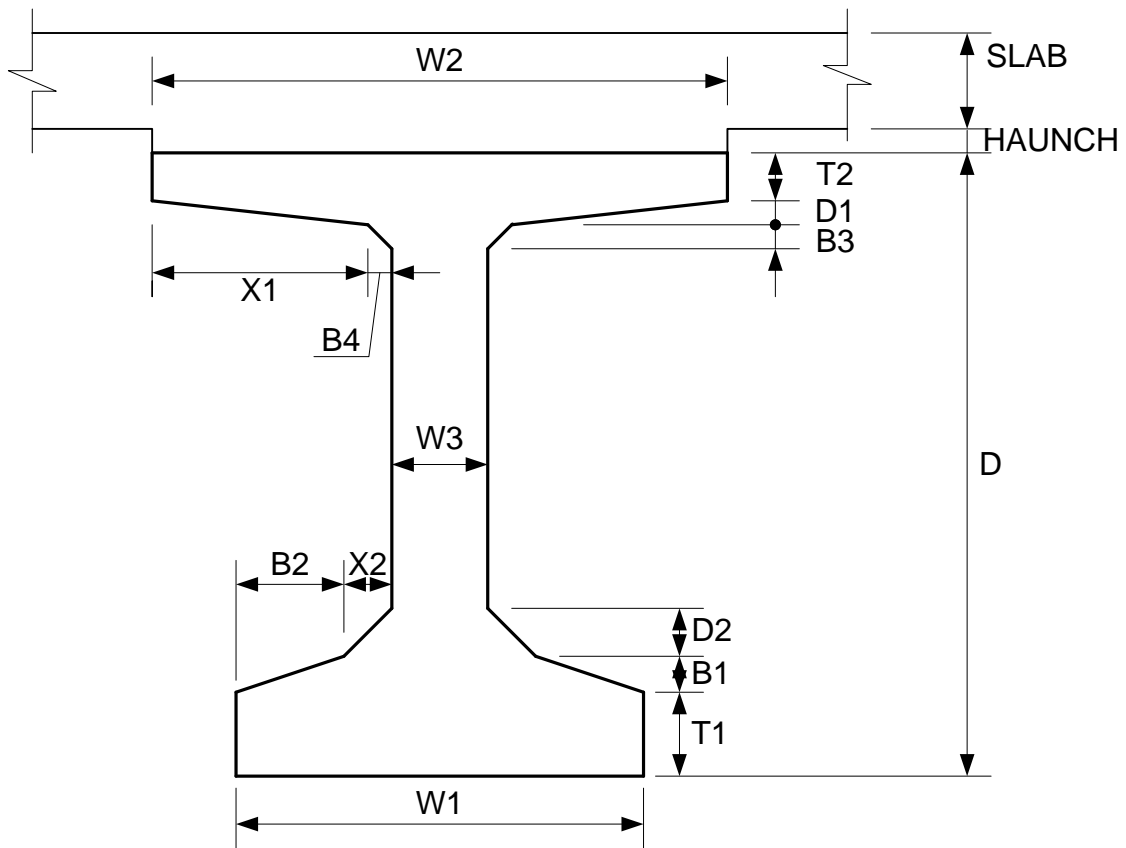

Figure 5.5.4 - Beam Dimensions – Bulb-Tee Beams

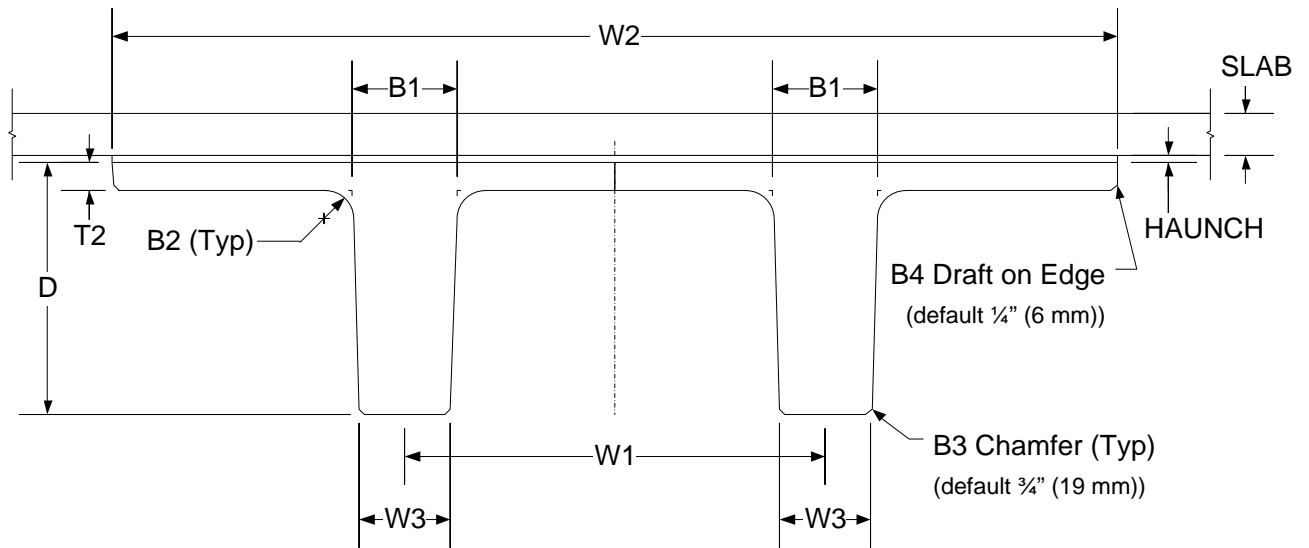

Figure 5.5.5 - Beam Dimensions – Double-Tee (NEXT) Beams

**5.7 REINFORCED CONCRETE BEAM/SLAB DIMENSIONS**

For RC T-beam, RC I-beam and RC slab sections, enter all applicable dimensions and reinforcement steel areas and locations. All dimensions and distances are entered either in inches (U.S.) or mm (SI). Reinforcement steel areas are entered either in in<sup>2</sup> (U.S.) or mm<sup>2</sup> (SI).

Refer to Figure 5.6.1 for T-beam dimensions, Figure 5.6.2 for I-beam dimensions and Figure 5.6.3 for slab dimensions.

**TYPE**

Enter one of the following codes to define the type of section:

Enter "T" if the section is a reinforced concrete T-beam.

Enter "I" if the section is a reinforced concrete I-beam.

Enter "S" if the section is a reinforced concrete slab.

Enter "P" if the section is a reinforced concrete plank beam.

**DEPTH**

Enter the gross depth of the section including the integral wearing surface – in or mm.

**WEARING SURFACE THICKNESS**

Enter the depth of the integral wearing surface – in or mm.

**TOP FLANGE WIDTH**

For a reinforced concrete beam (I-beam or T-beam), enter the tributary width of the top flange (i.e., beam spacing) - in or mm. This dimension is used to compute gross section properties for weight and stiffness calculations.

Leave blank for a reinforced concrete slab or a plank beam (RC Types "S" and "P"). The tributary section width for a slab is assumed to be 1 ft (12 in) or 1 m (1000 mm). The tributary section width for a plank beam is assumed to be equal to the effective slab width entered in the Slab Dimensions and Properties data line.

**TOP FLANGE THICKNESS**

For a reinforced concrete beam (I-beam or T-beam), enter the top flange thickness including the integral wearing surface - in or mm.

For a reinforced concrete slab or plank, enter the slab thickness including the integral wearing surface - in or mm.

**TOP FLANGE FILLET HORZ**

For a reinforced concrete beam (I-beam or T-beam), enter the horizontal dimension of the top flange fillet - in or mm.

Leave blank for a reinforced concrete slab or plank.

**TOP FLANGE FILLET VERT**

For a reinforced concrete beam (I-beam or T-beam), enter the vertical dimension of the top flange fillet - in or mm.

Leave blank for a reinforced concrete slab or plank.

**TOP WEB THICKNESS**

For a reinforced concrete beam (I-beam or T-beam), enter the thickness at the top of the web - in or mm.

Leave blank for a reinforced concrete slab or plank.

**BOTTOM WEB THICKNESS**

For a reinforced concrete beam (I-beam or T-beam), enter the thickness at the bottom of the web - in or mm.

Leave blank for a reinforced concrete slab or plank.

**AREA BOTTOM REINF**

For a reinforced concrete beam (I-beam or T-beam), enter the total area of the bottom longitudinal reinforcement - in<sup>2</sup> or mm<sup>2</sup>.

For a reinforced concrete slab or plank, enter the total bottom longitudinal reinforcement in the effective section width, assumed to be 1 ft or 1 m - in<sup>2</sup> or mm<sup>2</sup>.

**DISTNACE TO BOTTOM REINF**

Enter the distance from the bottom of the section to the c.g. of the bottom reinforcement – in or mm.

**BOTTOM FLANGE WIDTH**

For a reinforced concrete I-beam, enter the bottom flange width - in or mm.

Leave blank for a reinforced concrete slab or plank and for a reinforced concrete T-beam.

**Chapter 5 Input Data Requirements**

**BOTTOM FLANGE THICKNESS**

For a reinforced concrete I-beam, enter the bottom flange thickness - in or mm.

Leave blank for a reinforced concrete slab or plank and for a reinforced concrete T-beam.

**BOTTOM FLANGE FILLET HORZ**

For a reinforced concrete I-beam, enter the horizontal dimension of the bottom flange fillet - in or mm.

Leave blank for a reinforced concrete slab or plank and for a reinforced concrete T-beam.

**BOTTOM FLANGE FILLET VERT**

For a reinforced concrete I-beam, enter the vertical dimension of the bottom flange fillet - in or mm.

Leave blank for a reinforced concrete slab or plank and for a reinforced concrete T-beam.

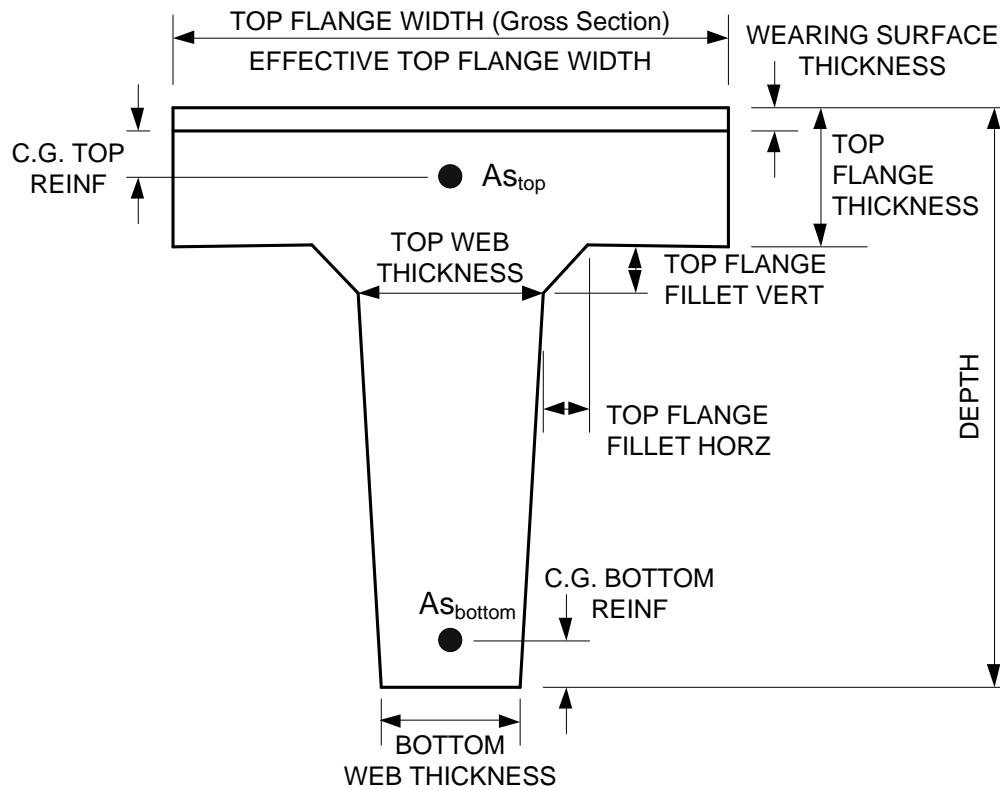

**Reinforced Concrete T-beam Dimensions**

Figure 5.6.1 - Beam Dimensions – Reinforced Concrete T-beam

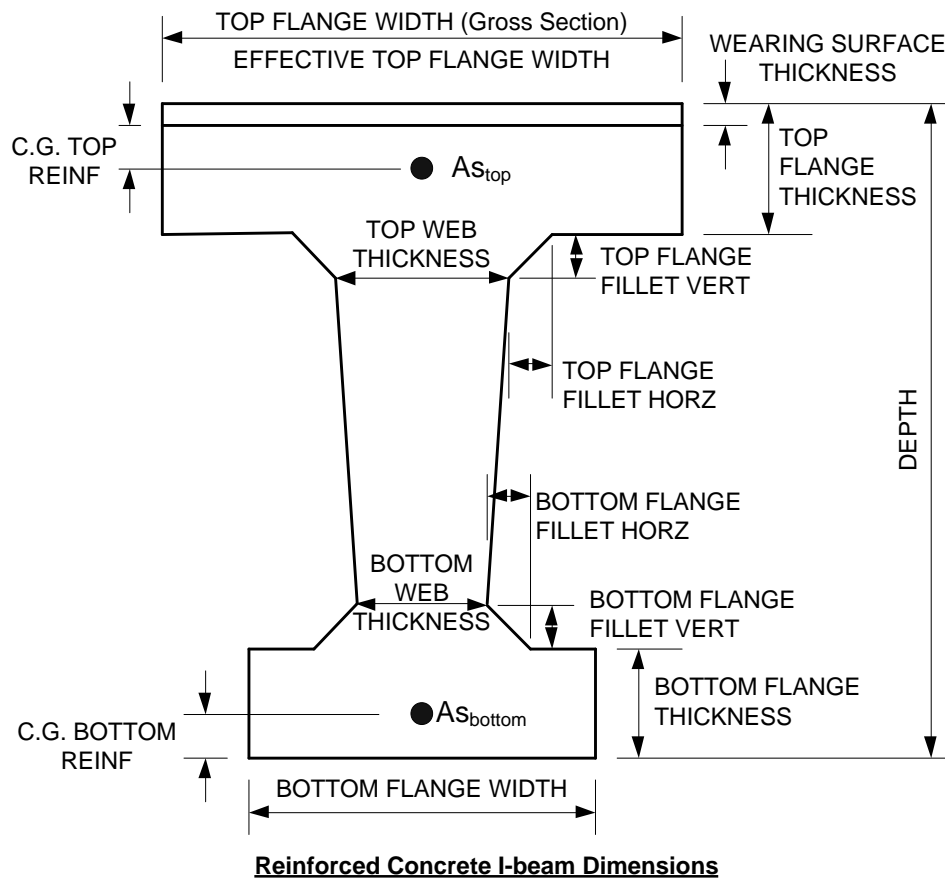

Figure 5.6.2 - Beam Dimensions – Reinforced Concrete I-beam

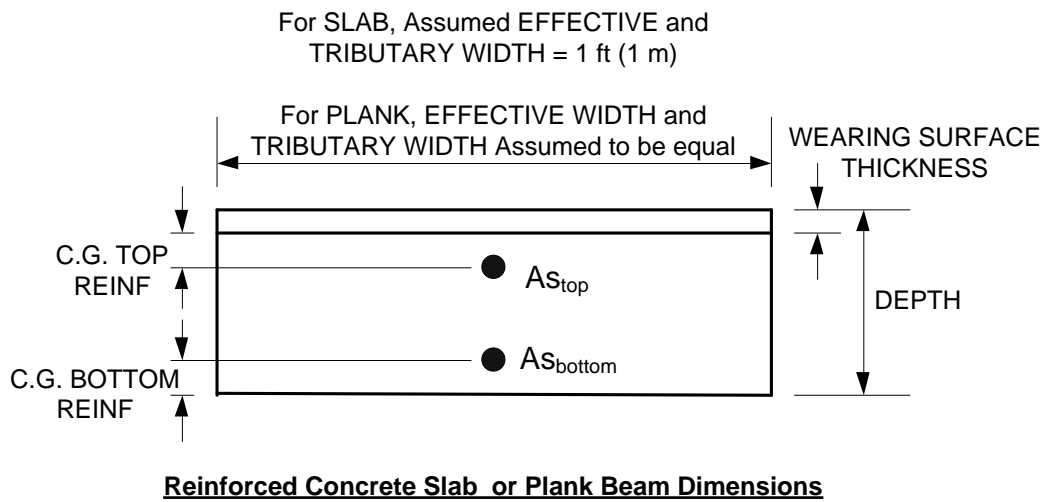

Figure 5.6.3 - Beam Dimensions – Reinforced Concrete Slab or Plank

## Chapter 5 Input Data Requirements

### 5.8 SECTION LOSS/ADDITION OR BOLT HOLE DATA

If the number of section losses/additions entered in BEAM DATA is greater than zero, enter the following for each section.

Assume a coordinate system where the x-x axis runs along the bottom of the beam cross section and y-y axis passes through the midpoint of the web thickness. See Figure 5.7.1 on page 5-27.

#### SECTION CODE

Enter one of the following codes to define the type of section.

Enter "L" for section loss.

Enter "H" for bolt hole.

Enter "A" for section addition.

#### X COORDINATE

Distance along x-x axis from the origin to the c.g. of the section – inches or mm.

#### Y COORDINATE

Distance along y-y axis from the origin to the c.g. of the section – inches or mm.

#### SECTION WIDTH

Section dimensions which is parallel to the x-x axis – inches or mm.

#### SECTION DEPTH

Section dimensions which is parallel to the y-y axis – inches or mm.

#### SECTION Fy

The yield strength of the steel of which the section was/is composed – psi or MPa.

If left blank, the program will use the Fy WEB value.

## Chapter 5 Input Data Requirements

### LOCATION

Enter one of the following component codes to designate the location of the section loss or hole:

“1” – for the top cover plate of a WF section or the top plate for other section types.

“2” – for the top flange of a WF section

“3” – for the top left angle of a built-up section.

“4” – for the top right angle of a built-up section.

“5” – for the web.

“6” – for the bottom left angle of a built-up section

“7” – for the bottom right angle of a built-up section.

“8” – for the bottom flange of a WF section.

“9” – for the bottom cover plate of a WF section or the bottom plate for other section types.

If either “L” or “H” is entered for SECTION CODE, a LOCATION code must be entered.

If “A” is entered for SECTION CODE, leave blank.

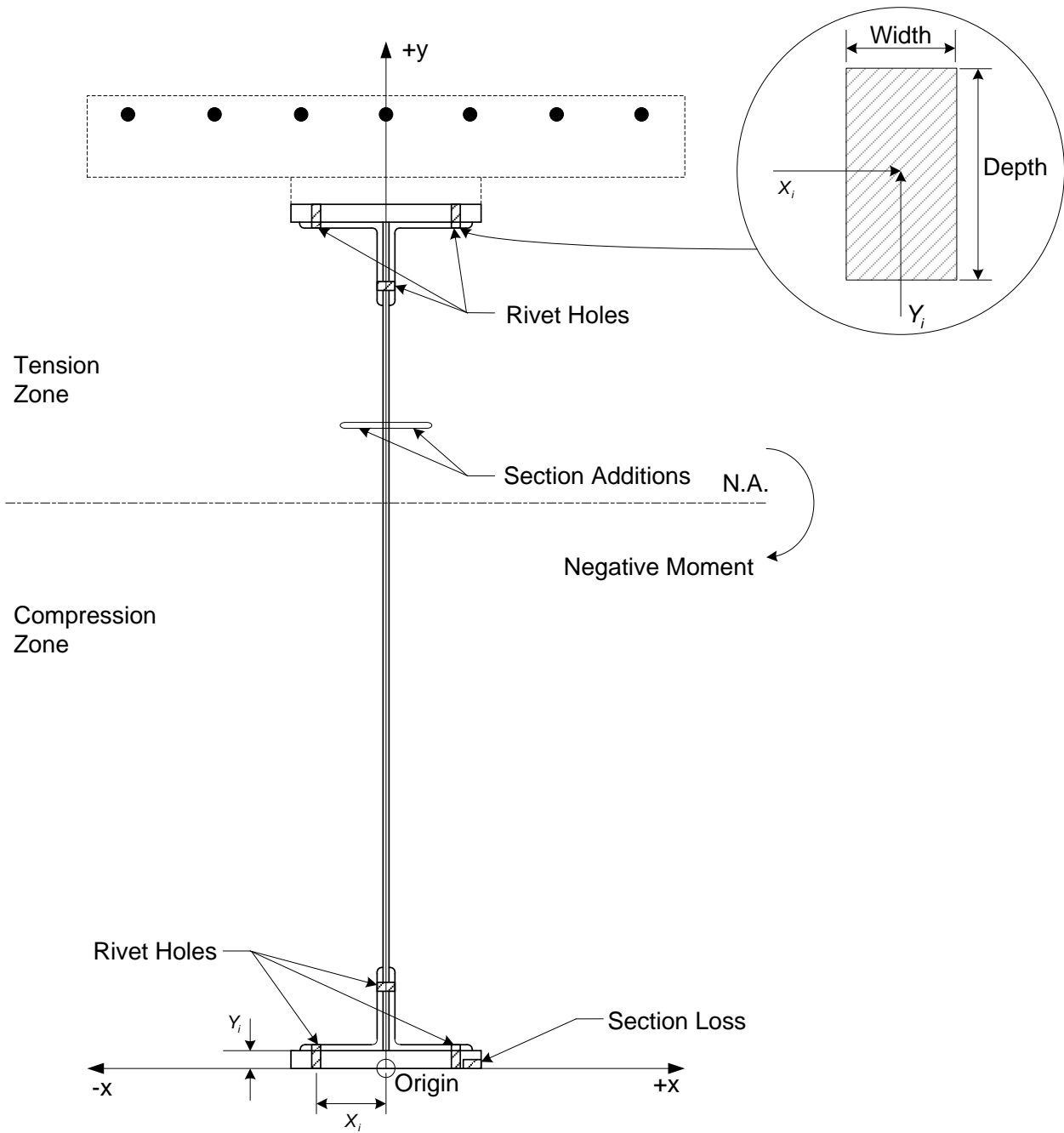

Figure 5.7.1 - Section Loss/Addition and Bolt Hole Coordinates

This page is intentionally left blank.

# 6

## ***OUTPUT DESCRIPTION***

### **6.1 GENERAL**

The printed output consists of a repeat of all input values and the computed values. For some computed values, in addition to a description, a notation is also printed which in most instances would correspond to the notation used in the LRFD Bridge Design Specifications. The units of all input and computed values are also printed. The output is printed in a line item format. The number of items printed varies depending on some input parameters such as MATERIAL, OUTPUT and COMP codes. Most of the computed values are self-explanatory. Refer to the Notation sub-sections of Section 5 – Concrete Structure and Section 6 – Steel Structures of the LRFD Bridge Design Specifications for further explanation of printed properties.

This page is intentionally left blank.

# 7

## ***EXAMPLE PROBLEMS***

### **7.1 GENERAL**

Four example problems have been included to show various section properties calculated by the program. Refer to the INPUT DATA REQUIREMENTS section of this manual for these example problems as well as your specific problem.

### **7.2 EXAMPLE PROBLEM 1**

This is an example of a steel wide flange beam composite section subjected to a positive flexure. The dimensions and properties are specified in U.S. Customary units.

Figure 7.2.1 on page 7-2 shows the cross section of the steel member.

Figure 7.2.2 on page 7-3 shows the completed input data sheet.

Figure 7.2.3 on page 7-4 shows the output for this problem.

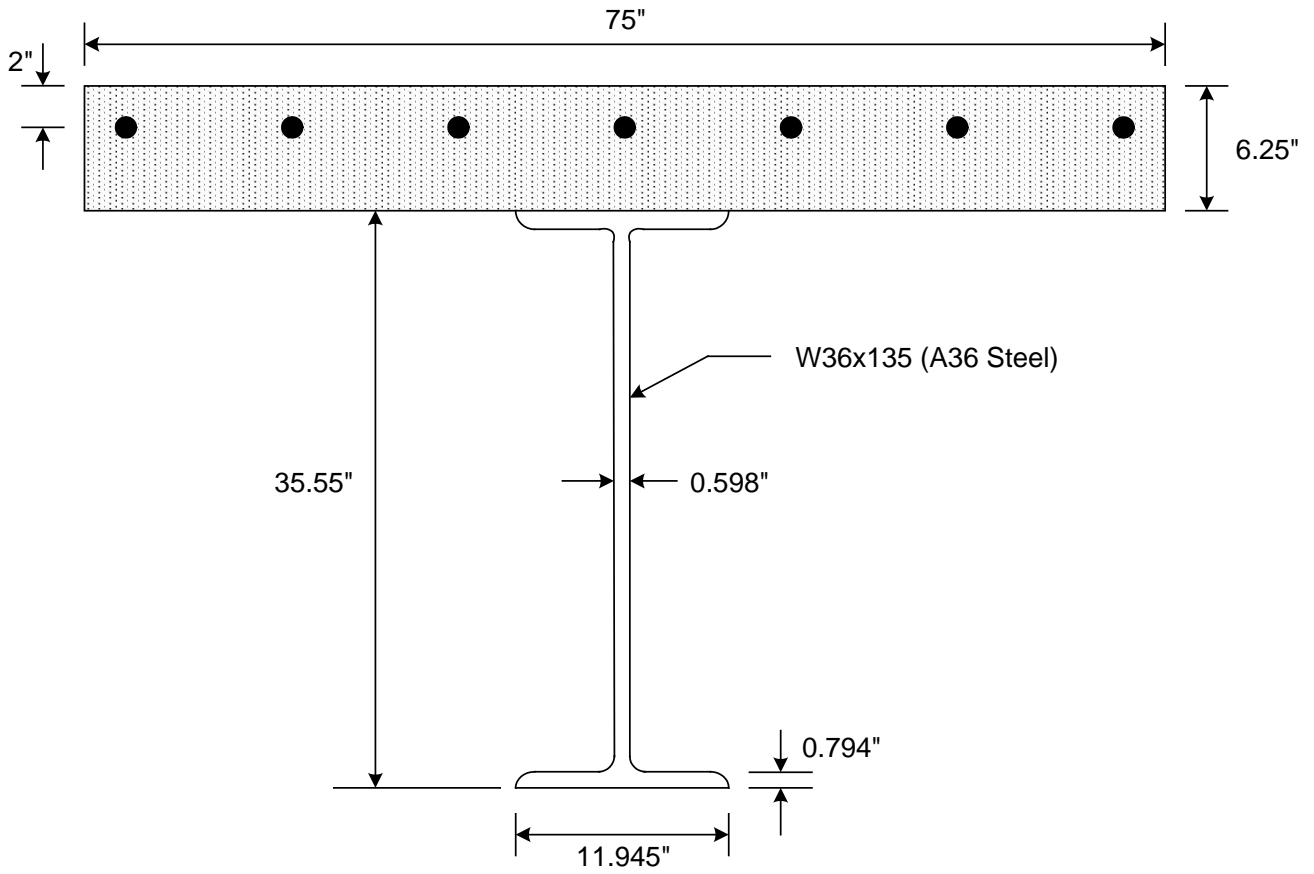

Composite Deck  
 $f'_c = 3000 \text{ psi}$   
Slab Reinf. =  $0.71 \text{ in}^2 / \text{ft}$   
 $f_y(\text{reinf}) = 50,000 \text{ psi}$

Figure 7.2.1 - Section for Example 1

BSP  
BEAM SECTION PROPERTIES

PROJECT IDENTIFICATION	
1 2	
#	EXAMPLE PROBLEM 1 - COMPOSITE WIDE FLANGE BEAM POSITIVE FLEXURE
#	
#	

SLAB DIMENSIONS AND PROPERTIES

UNITS	EFFECTIVE		SLAB F'c	MODULAR RATIO	P/S CONC BEAM or RC SLAB DATA			FLEXURE OUTPUT	# OF SECT LOSS/ADD	NEGLECT CMPR	SLAB CONCRETE UNIT WEIGHT FOR E <sub>c</sub>	BEAM CONCRETE UNIT WEIGHT FOR E <sub>c</sub>	INCL HAUNCH
	WIDTH	THICK			HAUNCH	AREA P/S STR or TOP REINF	C.G. P/S STR or TOP REINF						
1 2 3	9	14	19	25 27	37	43	49 50 51	60	53 54			66 67	
US	7.5 0.0	6.2 5	3 0 0.0	1 0 1 0 1 4	0.7 1	1.8 8	5 0 0.0 0 0	0	0				

STEEL BEAM DIMENSIONS AND PROPERTIES

SECT TYPE	WF BEAM MOD OR ANGLE VERT LEG	WF BEAM AREA OR ANGLE HORZ LEG	FLANGE OR ANGLE THICK	FLANGE WIDTH	WF BEAM OR WEB PLATE DEPTH	WEB THICK	TOP PLATE		BOTTOM PLATE		Fy WEB	Fy TOP	Fy BOT
							WIDTH	THICK	WIDTH	THICK			
1 2	10	16	22	28	34	40	45	51	56	62 63	69	75	
WF 7.8 2 0.0 0.0	3.9 8 1 1	9.4 5 0	7.9 4 0	3.5 5 5	0.5 9 8					Y 3 6 0 0 0			

UNSYMMETRICAL FLANGE

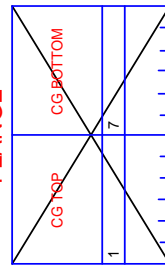

PREPARED BY .....

DATE ...../...../.....

SHEET ..... OF .....

Figure 7.2.2 - Input for Example 1

Chapter 7 Example Problems

BEAM SECTION PROPERTIES

PROGRAM P4353050  
VERSION 2.0.0.0

LAST UPDATED 03/31/2015

03/25/2015 11:05  
DOCUMENTATION 03/2015

INPUT: EX1.DAT

EXAMPLE PROBLEM 1 - COMPOSITE WIDE FLANGE BEAM POSITIVE FLEXURE  
CONSTRUCTION CONDITION PROPERTIES

<<<<<<<<<< INPUT VALUES >>>>>>>>>>

SLAB DIMENSIONS AND PROPERTIES:

UNITS: U  
MATERIAL: S  
EFFECTIVE SLAB WIDTH: 075.00 (in)  
EFFECTIVE SLAB THICKNESS: 06.25 (in)  
EFFECTIVE SLAB HAUNCH: 0.000 (in)  
SLAB F'c: 3000.0 (psi)  
MODULAR RATIO (SLAB REINF TO SLAB CONC): 10  
CONSTRUCTION MODULAR RATIO (SLAB REINF TO SLAB CONC): 14  
LONG SLAB REINF: 00000.71 (in<sup>2</sup>/ft)  
SLAB TOP TO REINF: 001.88 (in)  
Fy REINF: 050000 (psi)  
FLEXURE: P  
OUTPUT: 0  
NO. OF SECTION LOSS/ADDITION AND BOLT HOLE AREAS: 0  
NEGLECT CMPR: N/A for Steel Beams  
SLAB CONCRETE UNIT WEIGHT FOR Ec: N/A for Steel Beam  
BEAM CONCRETE UNIT WEIGHT FOR Ec: N/A for Steel Beam  
UNSYMMETRICAL FLANGE:  
INCLUDE HAUNCH: N/A for Steel Beam

STEEL BEAM DIMENSIONS AND PROPERTIES:

SECT TYPE: W  
WF BEAM M OF I: 00007820 (in<sup>4</sup>)  
WF BEAM AREA: 0039.8 (in<sup>2</sup>)  
FLANGE WIDTH: 11.945 (in)  
FLANGE THICK: 0.7940 (in)  
WF BEAM DEPTH: 035.55 (in)  
WEB THICK: 00.598 (in)  
TOP PLATE WIDTH: 0.000 (in)  
TOP PLATE THICK: 0.0000 (in)  
BOTTOM PLATE WIDTH: 0.000 (in)  
BOTTOM PLATE THICK: 0.0000 (in)  
COMPOSITE: Y  
Fy WEB: 036000 (psi)  
Fy TOP: 0.0000 (psi)  
Fy BOT: 0.0000 (psi)

Figure 7.2.3 - Output for Example 1

## Chapter 7 Example Problems

```
<<<<<<<<< COMPUTED VALUES >>>>>>>>>>

ELASTIC SECTION PROPERTIES (NON-COMPOSITE, POSITIVE FLEXURE):

Moment of Inertia, Ix: 7820.00 (in^4)
Moment of Inertia of Compression Flange, Iyc: 112.77 (in^4)
Moment of Inertia, Iy: 226.15 (in^4)
N.A. to Top of Steel: 17.77 (in)
N.A. to Bottom of Steel: 17.77 (in)
Section Modulus of Steel Top: 439.94 (in^3)
Section Modulus of Steel Bottom: 439.94 (in^3)
Radius of Gyration of Steel, ry: 2.40 (in)
Radius of Gyration of Compression Flange, r': 3.45 (in)

ELASTIC SECTION PROPERTIES (COMPOSITE, N=10, POSITIVE FLEXURE):

Moment of Inertia, Ix: 17374.65 (in^4)
First Moment of Inertia of Transformed Section, Q: 449.86 (in^3)
N.A. to Top of Steel: 6.47 (in)
N.A. to Top of Slab: 12.72 (in)
N.A. to C.G. Long. Reinf.: 10.84 (in)
N.A. to Bottom of Steel: 29.08 (in)
Section Modulus of Steel Top: 2684.59 (in^3)
Section Modulus of Slab Top: 1365.72 (in^3)
Section Modulus at C.G. Long. Slab Reinf.: 1602.53 (in^3)
Section Modulus of Steel Bottom 597.52 (in^3)

ELASTIC SECTION PROPERTIES (COMPOSITE, N=30, POSITIVE FLEXURE):

Moment of Inertia, Ix: 12771.92 (in^4)
N.A. to Top of Steel: 11.88 (in)
N.A. to Top of Slab: 18.13 (in)
N.A. to C.G. Long. Reinf.: 16.25 (in)
N.A. to Bottom of Steel: 23.67 (in)
Section Modulus of Steel Top: 1074.80 (in^3)
Section Modulus of Slab Top: 704.35 (in^3)
Section Modulus at C.G. Long. Slab Reinf.: 785.82 (in^3)
Section Modulus of Steel Bottom 539.65 (in^3)

ELASTIC SECTION PROPERTIES (COMPOSITE, N=14 - CONSTRUCTION, POSITIVE FLEXURE):

Moment of Inertia, Ix: 15872.10 (in^4)
N.A. to Top of Steel: 8.23 (in)
N.A. to Top of Slab: 14.48 (in)
N.A. to C.G. Long. Reinf.: 12.60 (in)
N.A. to Bottom of Steel: 27.32 (in)
Section Modulus of Steel Top: 1929.52 (in^3)
Section Modulus of Slab Top: 1096.45 (in^3)
Section Modulus at C.G. Long. Slab Reinf.: 1260.10 (in^3)
Section Modulus of Steel Bottom 580.88 (in^3)

PLASTIC SECTION PROPERTIES (COMPOSITE, POSITIVE FLEXURE):

Plastic N.A. to Top of Slab: 6.50 (in)
Plastic Moment Capacity, Mp: 28842.1 (kip-in)
Depth of Web in Compression at Plastic Moment, Dcp: 0.00 (in)

ADDITIONAL PROPERTIES (POSITIVE FLEXURE):

Distance Between C.G.'s of Steel Section and Slab: 20.90 (in)
Longitudinal Stiffness Parameter, Kg: 252050.38 (in^4)
```

Figure 7.2.3 - Output for Example 1 (cont.)

## **Chapter 7      Example Problems**

### **7.3 EXAMPLE PROBLEM 2**

This is an example of a welded plate girder section subjected to negative flexure. The dimensions and properties are specified in metric (SI) units.

Figure 7.3.1 on page 7-7 shows the cross section of the steel member.

Figure 7.3.2 on page 7-8 shows the completed input data sheet.

Figure 7.3.3 on page 7-9 shows the output for this problem.

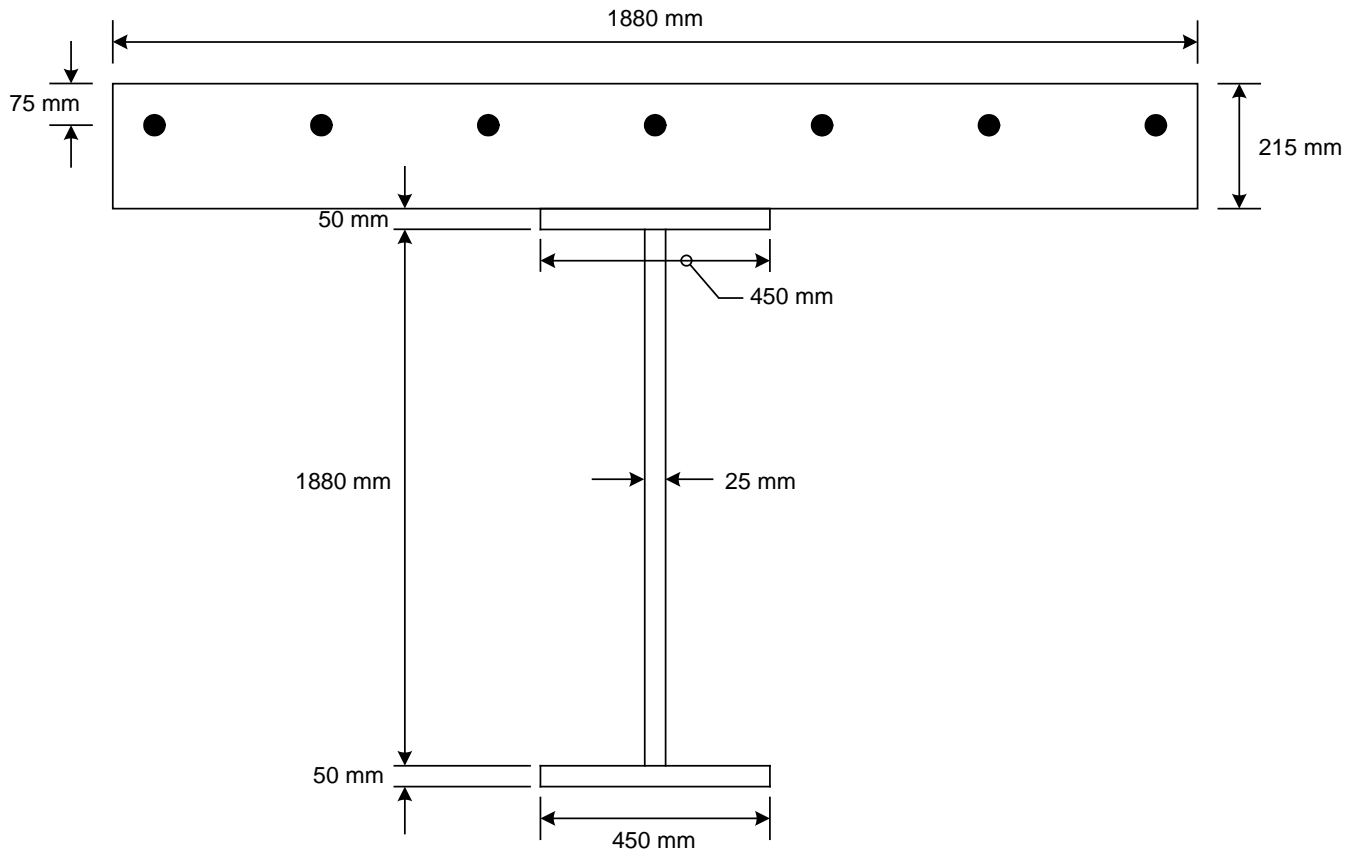

Composite Deck  
 $f'c = 24 \text{ MPa}$   
Slab Reinf. =  $1.60 \text{ mm}^2 / \text{m}$   
 $f_y(\text{reinf}) = 345 \text{ MPa}$   
 $f_y(\text{plates}) = 250 \text{ MPa}$

Figure 7.3.1 - Section for Example 2

BSP  
BEAM SECTION PROPERTIES

PROJECT IDENTIFICATION	
1	2
#	EXAMPLE PROBLEM 2 - COMPOSITE PLATE GIRDER, NEGATIVE FLEXURE
#	
#	

SLAB DIMENSIONS AND PROPERTIES

UNITS	EFFECTIVE		SLAB F'c	MODULAR RATIO	P/S CONC BEAM or RC SLAB DATA			FLEXURE OUTPUT	# OF SECT LOSS/ADD	NEGLECT CMR	SLAB CONCRETE UNIT WEIGHT FOR E <sub>c</sub>	BEAM CONCRETE UNIT WEIGHT FOR E <sub>c</sub>	UNSYM FLANGE INCL HAUNCH						
	WIDTH	THICK			HAUNCH	AREA P/S STR or TOP REINF	P/S STR or TOP REINF							C.G.	BEAM F'c or Fy REINF				
1	2	3	9	14	19	25	27	29	37	43	49	50	51	53	54	60	66	67	
MS	1	8	0	0	2	1	5	0	0	7	5	0	3	4	5	0	0	0	0

STEEL BEAM DIMENSIONS AND PROPERTIES

SECT TYPE	WF BEAM MOD I OR ANGLE VERT LEG	WF BEAM AREA OR ANGLE HORZ LEG	FLANGE OR ANGLE THICK	FLANGE WIDTH	WF BEAM OR WEB PLATE DEPTH	WEB THICK	TOP PLATE		BOTTOM PLATE		COMPOSITE	Fy WEB	Fy TOP	Fy BOT
							WIDTH	THICK	WIDTH	THICK				
1	2	10	16	22	28	34	40	45	51	56	62	63	69	75
P					1	8	0	0	5	0	0	5	0	0

UNSYMMETRICAL FLANGE

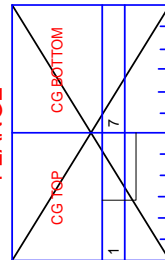

PREPARED BY .....

DATE ...../...../.....

SHEET ..... OF .....

Figure 7.3.2 - Input for Example 2

## Chapter 7 Example Problems

```

                                BEAM SECTION PROPERTIES
PROGRAM P4353050                03/25/2015 11:05
VERSION 2.0.0.0                LAST UPDATED 03/31/2015  DOCUMENTATION 03/2015

INPUT: EX2.DAT

EXAMPLE PROBLEM 2 - COMPOSITE PLATE GIRDER NEGATIVE FLEXURE

<<<<<<<<<<  INPUT VALUES  >>>>>>>>>>

SLAB DIMENSIONS AND PROPERTIES:

UNITS: M
MATERIAL: S
EFFECTIVE SLAB WIDTH: 1880.0 (mm)
EFFECTIVE SLAB THICKNESS: 215.0 (mm)
EFFECTIVE SLAB HAUNCH: 0.000 (mm)
SLAB F'c: 024.00 (MPa)
MODULAR RATIO (SLAB REINF TO SLAB CONC): 08
CONSTRUCTION MODULAR RATIO (SLAB REINF TO SLAB CONC): 0.
LONG SLAB REINF: 001600.0 (mm^2/m)
SLAB TOP TO REINF: 0075.0 (mm)
Fy REINF: 345.00 (MPa)
FLEXURE: N
OUTPUT: 0
NO. OF SECTION LOSS/ADDITION AND BOLT HOLE AREAS: 0
NEGLECT CMR: N/A for Steel Beams
SLAB CONCRETE UNIT WEIGHT FOR Ec: N/A for Steel Beam
BEAM CONCRETE UNIT WEIGHT FOR Ec: N/A for Steel Beam
UNSYMMETRICAL FLANGE:
INCLUDE HAUNCH: N/A for Steel Beam

STEEL BEAM DIMENSIONS AND PROPERTIES:

SECT TYPE: P
WEB PLATE DEPTH: 1800.0 (mm)
WEB PLATE THICK: 0025.0 (mm)
TOP PLATE WIDTH: 450.0 (mm)
TOP PLATE THICK: 0050.0 (mm)
BOTTOM PLATE WIDTH: 450.0 (mm)
BOTTOM PLATE THICK: 0050.0 (mm)
COMPOSITE: Y
Fy WEB: 0250.0 (MPa)
Fy TOP: 0.0000 (MPa)
Fy BOT: 0.0000 (MPa)
```

Figure 7.3.3 - Output for Example 2

## Chapter 7 Example Problems

```
<<<<<<<<< COMPUTED VALUES >>>>>>>>>>

ELASTIC SECTION PROPERTIES (NON-COMPOSITE, NEGATIVE FLEXURE):

Moment of Inertia, Ix: 5.0662E+10 (mm^4)
Moment of Inertia of Compression Flange, Iyc: 3.796875E+08 (mm^4)
Moment of Inertia, Iy: 7.6172E+08 (mm^4)
N.A. to Top of Steel: 950.0 (mm)
N.A. to Bottom of Steel: 950.0 (mm)
Section Modulus of Steel Top: 5.3329E+07 (mm^3)
Section Modulus of Steel Bottom: 5.3329E+07 (mm^3)
Radius of Gyration of Steel, ry: 92.0 (mm)
Radius of Gyration of Compression Flange, r': 129.9 (mm)

ELASTIC SECTION PROPERTIES (COMPOSITE, NEGATIVE FLEXURE):

Moment of Inertia, Ix: 5.4121E+10 (mm^4)
First Moment of Inertia of Transformed Section, Q: 3.1727E+06 (mm^3)
N.A. to Top of Steel: 914.7 (mm)
N.A. to C.G. Long. Reinf.: 1054.7 (mm)
N.A. to Bottom of Steel: 985.3 (mm)
Section Modulus of Steel Top: 5.9165E+07 (mm^3)
Section Modulus of Slab Reinf.: 5.1312E+07 (mm^3)
Section Modulus of Steel Bottom: 5.4931E+07 (mm^3)

PLASTIC SECTION PROPERTIES (COMPOSITE, NEGATIVE FLEXURE):

Plastic N.A. to Top of Slab: 1082.0 (mm)
Plastic Moment Capacity, Mp: 16556.61 (kN-m)
Depth of Web in Compression at Plastic Moment, Dcp: 983.0 (mm)

ADDITIONAL PROPERTIES (NEGATIVE FLEXURE):

Distance Between C.G.'s of Steel Section and Slab: 1090.0 (mm)
Longitudinal Stiffness Parameter, Kg: 1.2607E+12 (mm^4)
```

Figure 7.3.3 – Output for Example 2 (cont.)

## **Chapter 7      Example Problems**

### **7.4 EXAMPLE PROBLEM 3**

This is an example of a steel riveted built-up section beam composite section subjected to a positive flexure. The dimensions and properties are specified in U.S. Customary units.

Figure 7.4.1 on page 7-12 shows the cross section of the steel member.

Figure 7.4.2 on page 7-13 shows the completed input data sheet.

Figure 7.4.3 on page 7-15 shows the output for this problem.

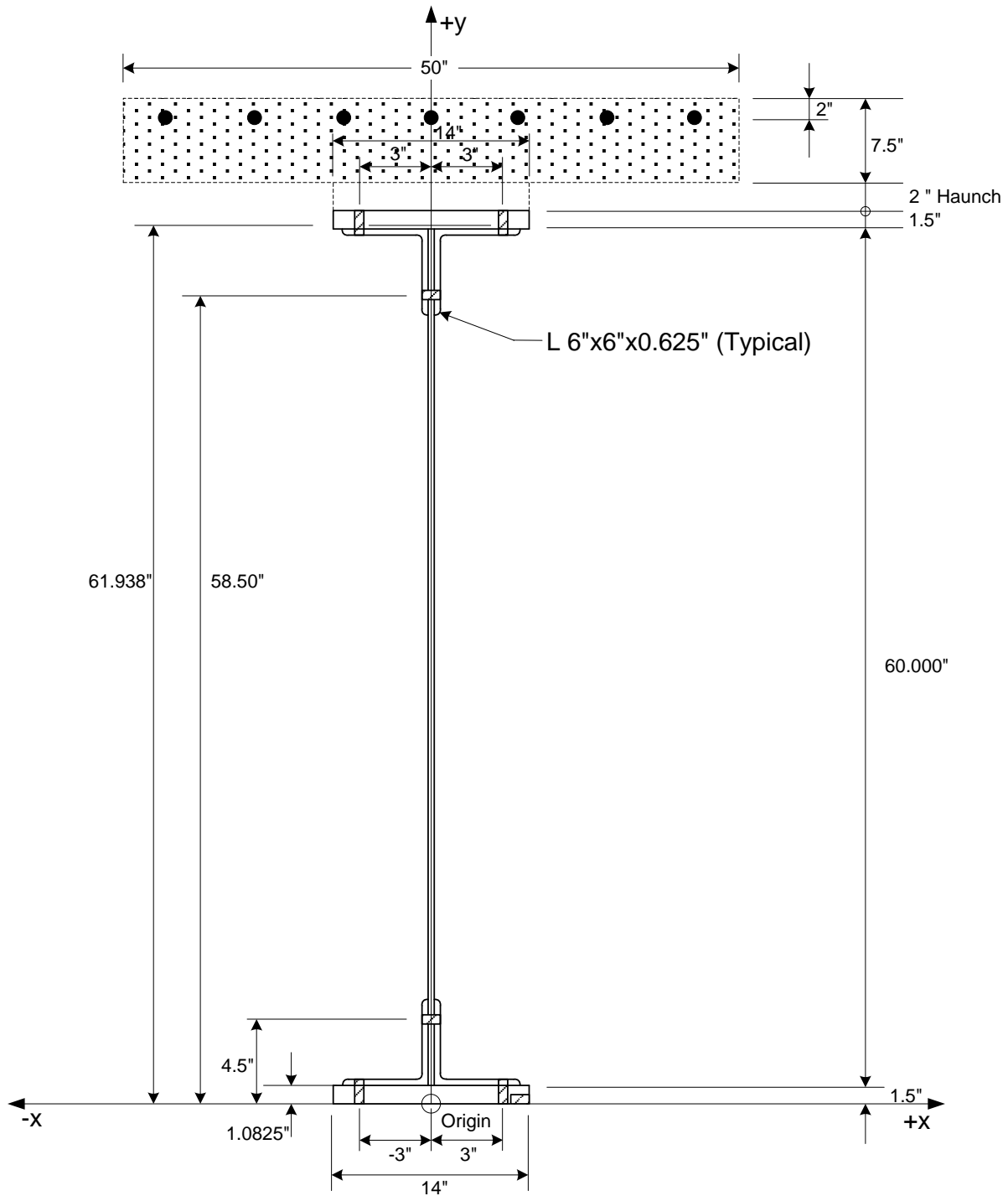

Composite Deck  
 $f'_c = 4000 \text{ psi}$   
 Slab Reinf. =  $0.72 \text{ in}^2 / \text{ft}$   
 $f_y(\text{reinf}) = 40,000 \text{ psi}$   
 $f_y(\text{plates}) = 36,000 \text{ psi}$   
 $f_y(\text{angles}) = 36,000 \text{ psi}$   
 Rivet Hole Dia. =  $0.5''$

Figure 7.4.1 - Section for Example 3

BSP  
BEAM SECTION PROPERTIES

PROJECT IDENTIFICATION	
1	2
#	EXAMPLE PROBLEM 3 - COMPOSITE RIVETTED BUILT-UP SECTION, NEG. FLEXURE
#	
#	

SLAB DIMENSIONS AND PROPERTIES

UNITS	EFFECTIVE		SLAB F'c	MODULAR RATIO	CONSTRUCTION RATIO	P/S CONC BEAM or RC SLAB DATA			FLEXURE OUTPUT	# OF SECT LOSS/ADD	NEGLECT CMFR	SLAB CONCRETE UNIT WEIGHT FOR E <sub>c</sub>	BEAM CONCRETE UNIT WEIGHT FOR E <sub>c</sub>	UNSYM FLANGE INCL HAUNCH				
	WIDTH	THICK				HAUNCH	AREA P/S STR or TOP REINF	C.G. P/S STR or TOP REINF							BEAM F'c or Fy REINF			
1	2	3	4	5	6	7	8	9	10	11	12	13	14	15				
US	5.0	7.5	2.00	4.000	8	25	27	29	37	43	49	50	51	53	54	60	66	67

STEEL BEAM DIMENSIONS AND PROPERTIES

SECT TYPE	WF BEAM M OF I OR ANGLE VERT LEG	WF BEAM AREA OR ANGLE HORZ LEG	FLANGE OR ANGLE THICK	FLANGE WIDTH	WF BEAM OR WEB PLATE DEPTH	WEB THICK	TOP PLATE		BOTTOM PLATE		Fy WEB	Fy TOP	Fy BOT	
							WIDTH	THICK	WIDTH	THICK				
1	2	3	4	5	6	7	8	9	10	11	12	13	14	
B	6.00	6.00	0.625	22	28	34	40	45	51	56	62	63	69	75
					6.00	0.50	1.40	1.50	1.40	1.50	1.50	1.50	3.60	0.00

UNSYMMETRICAL  
FLANGE

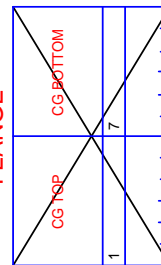

PREPARED BY .....

DATE .....

SHEET ..... OF .....

Figure 7.4.2 - Input for Example 3



**Chapter 7 Example Problems**

BEAM SECTION PROPERTIES

PROGRAM P4353050  
VERSION 2.0.0.0

LAST UPDATED 03/31/2015

03/25/2015 13:18  
DOCUMENTATION 03/2015

INPUT: EX3.DAT

EXAMPLE PROBLEM 3 - COMPOSITE RIVETTED BUILT-UP SECTION NEG. FLEXURE

<<<<<<<<<< INPUT VALUES >>>>>>>>>>

SLAB DIMENSIONS AND PROPERTIES:

UNITS: U  
MATERIAL: S  
EFFECTIVE SLAB WIDTH: 000050 (in)  
EFFECTIVE SLAB THICKNESS: 007.5 (in)  
EFFECTIVE SLAB HAUNCH: 02.00 (in)  
SLAB F'c: 004000 (psi)  
MODULAR RATIO (SLAB REINF TO SLAB CONC): 08  
CONSTRUCTION MODULAR RATIO (SLAB REINF TO SLAB CONC): 0.  
LONG SLAB REINF: 00000.72 (in^2/ft)  
SLAB TOP TO REINF: 002.00 (in)  
Fy REINF: 040000 (psi)  
FLEXURE: N  
OUTPUT: 0  
NO. OF SECTION LOSS/ADDITION AND BOLT HOLE AREAS: 14  
NEGLECT CMPR: N/A for Steel Beams  
SLAB CONCRETE UNIT WEIGHT FOR Ec: N/A for Steel Beam  
BEAM CONCRETE UNIT WEIGHT FOR Ec: N/A for Steel Beam  
UNSYMMETRICAL FLANGE:  
INCLUDE HAUNCH: N/A for Steel Beam

STEEL BEAM DIMENSIONS AND PROPERTIES:

SECT TYPE: B  
ANGLE VERT LEG: 00006.00 (in)  
ANGLE HORZ LEG: 006.00 (in)  
ANGLE THICK: 00.625 (in)  
WEB PLATE DEPTH: 060.00 (in)  
WEB PLATE THICK: 000.50 (in)  
TOP PLATE WIDTH: 14.00 (in)  
TOP PLATE THICK: 001.50 (in)  
BOTTOM PLATE WIDTH: 14.00 (in)  
BOTTOM PLATE THICK: 001.50 (in)  
COMPOSITE: Y  
Fy WEB: 036000 (psi)  
Fy TOP: 036000 (psi)  
Fy BOT: 036000 (psi)

SECTION LOSS/ADDITION AND BOLT HOLE DIMENSIONS AND LOCATIONS:

SECTION NO.: 1  
SECTION LOSS/ADDITION OR BOLT HOLE: H  
X COORDINATE: -03.00 (in)  
Y COORDINATE: 0.7500 (in)  
SECTION WIDTH: 000.50 (in)  
SECTION DEPTH: 01.500 (in)  
SECTION Fy: 0.0000 (psi)  
LOCATION: 9

Figure 7.4.3 - Output for Example 3

## Chapter 7 Example Problems

```
SECTION NO.: 2
SECTION LOSS/ADDITION OR BOLT HOLE: H
X COORDINATE: 003.00 (in)
Y COORDINATE: 0.7500 (in)
SECTION WIDTH: 000.50 (in)
SECTION DEPTH: 01.500 (in)
SECTION Fy: 0.0000 (psi)
LOCATION: 9

SECTION NO.: 3
SECTION LOSS/ADDITION OR BOLT HOLE: H
X COORDINATE: -03.00 (in)
Y COORDINATE: 1.8125 (in)
SECTION WIDTH: 000.50 (in)
SECTION DEPTH: 00.625 (in)
SECTION Fy: 0.0000 (psi)
LOCATION: 6

SECTION NO.: 4
SECTION LOSS/ADDITION OR BOLT HOLE: H
X COORDINATE: 003.00 (in)
Y COORDINATE: 1.8125 (in)
SECTION WIDTH: 000.50 (in)
SECTION DEPTH: 00.625 (in)
SECTION Fy: 0.0000 (psi)
LOCATION: 7

SECTION NO.: 5
SECTION LOSS/ADDITION OR BOLT HOLE: H
X COORDINATE: -.5625 (in)
Y COORDINATE: 4.5000 (in)
SECTION WIDTH: 00.625 (in)
SECTION DEPTH: 00.500 (in)
SECTION Fy: 0.0000 (psi)
LOCATION: 6

SECTION NO.: 6
SECTION LOSS/ADDITION OR BOLT HOLE: H
X COORDINATE: 000.00 (in)
Y COORDINATE: 4.5000 (in)
SECTION WIDTH: 000.50 (in)
SECTION DEPTH: 00.500 (in)
SECTION Fy: 0.0000 (psi)
LOCATION: 5

SECTION NO.: 7
SECTION LOSS/ADDITION OR BOLT HOLE: H
X COORDINATE: 0.5625 (in)
Y COORDINATE: 4.5000 (in)
SECTION WIDTH: 00.625 (in)
SECTION DEPTH: 00.500 (in)
SECTION Fy: 0.0000 (psi)
LOCATION: 7

SECTION NO.: 8
SECTION LOSS/ADDITION OR BOLT HOLE: H
X COORDINATE: -.5625 (in)
Y COORDINATE: 58.500 (in)
SECTION WIDTH: 00.625 (in)
SECTION DEPTH: 00.500 (in)
SECTION Fy: 0.0000 (psi)
LOCATION: 3
```

Figure 7.4.3 - Output for Example 3 (cont.)

## Chapter 7 Example Problems

```
SECTION NO.: 9
SECTION LOSS/ADDITION OR BOLT HOLE: H
X COORDINATE: 000.00 (in)
Y COORDINATE: 58.500 (in)
SECTION WIDTH: 000.50 (in)
SECTION DEPTH: 00.500 (in)
SECTION Fy: 0.0000 (psi)
LOCATION: 5

SECTION NO.: 10
SECTION LOSS/ADDITION OR BOLT HOLE: H
X COORDINATE: 0.5625 (in)
Y COORDINATE: 58.500 (in)
SECTION WIDTH: 00.625 (in)
SECTION DEPTH: 00.500 (in)
SECTION Fy: 0.0000 (psi)
LOCATION: 4

SECTION NO.: 11
SECTION LOSS/ADDITION OR BOLT HOLE: H
X COORDINATE: -03.00 (in)
Y COORDINATE: 61.188 (in)
SECTION WIDTH: 000.50 (in)
SECTION DEPTH: 00.625 (in)
SECTION Fy: 0.0000 (psi)
LOCATION: 3

SECTION NO.: 12
SECTION LOSS/ADDITION OR BOLT HOLE: H
X COORDINATE: 003.00 (in)
Y COORDINATE: 61.188 (in)
SECTION WIDTH: 000.50 (in)
SECTION DEPTH: 00.625 (in)
SECTION Fy: 0.0000 (psi)
LOCATION: 4

SECTION NO.: 13
SECTION LOSS/ADDITION OR BOLT HOLE: H
X COORDINATE: -03.00 (in)
Y COORDINATE: 62.250 (in)
SECTION WIDTH: 000.50 (in)
SECTION DEPTH: 01.500 (in)
SECTION Fy: 0.0000 (psi)
LOCATION: 1

SECTION NO.: 14
SECTION LOSS/ADDITION OR BOLT HOLE: H
X COORDINATE: 003.00 (in)
Y COORDINATE: 62.250 (in)
SECTION WIDTH: 000.50 (in)
SECTION DEPTH: 01.500 (in)
SECTION Fy: 0.0000 (psi)
LOCATION: 1
```

Figure 7.4.3 - Output for Example 3 (cont.)

## Chapter 7 Example Problems

```
<<<<<<<<< COMPUTED VALUES >>>>>>>>>>

ELASTIC SECTION PROPERTIES (NON-COMPOSITE, NEGATIVE FLEXURE):

Moment of Inertia, Ix: 71545.05 (in^4)
Moment of Inertia of Compression Flange, Iyc: 444.73 (in^4)
Moment of Inertia, Iy: 894.75 (in^4)
N.A. to Top of Steel: 31.50 (in)
N.A. to Bottom of Steel: 31.50 (in)
Section Modulus of Steel Top: 2271.27 (in^3)
Section Modulus of Steel Bottom: 2271.27 (in^3)
Radius of Gyration of Steel, ry: 2.98 (in)
Radius of Gyration of Compression Flange, r': 3.95 (in)

ELASTIC SECTION PROPERTIES (COMPOSITE, NEGATIVE FLEXURE):

Moment of Inertia, Ix: 75975.71 (in^4)
First Moment of Inertia of Transformed Section, Q: 113.61 (in^3)
N.A. to Top of Steel: 30.37 (in)
N.A. to C.G. Long. Reinf.: 37.87 (in)
N.A. to Bottom of Steel: 32.63 (in)
Section Modulus of Steel Top: 2501.76 (in^3)
Section Modulus of Slab Reinf.: 2006.28 (in^3)
Section Modulus of Steel Bottom: 2328.32 (in^3)

PLASTIC SECTION PROPERTIES (COMPOSITE, NEGATIVE FLEXURE):

Plastic N.A. to Top of Slab: 37.67 (in)
Plastic Moment Capacity, Mp: 96114.5 (kip-in)
Depth of Web in Compression at Plastic Moment, Dcp:32.71 (in)

ADDITIONAL PROPERTIES (NEGATIVE FLEXURE):

Distance Between C.G.'s of Steel Section and Slab: 39.00 (in)
Longitudinal Stiffness Parameter, Kg: 1794483.87 (in^4)
```

Figure 7.4.3 - Output for Example 3 (cont.)

## **Chapter 7      Example Problems**

### **7.5 EXAMPLE PROBLEM 4**

This is an example of a composite prestressed concrete spread box beam. The dimensions and properties are specified in U.S. Customary units.

Figure 7.5.1 on page 7-20 shows the cross section of the prestressed concrete member.

Figure 7.5.2 on page 7-21 shows the completed input data sheet.

Figure 7.5.3 on page 7-23 shows the output for this problem.

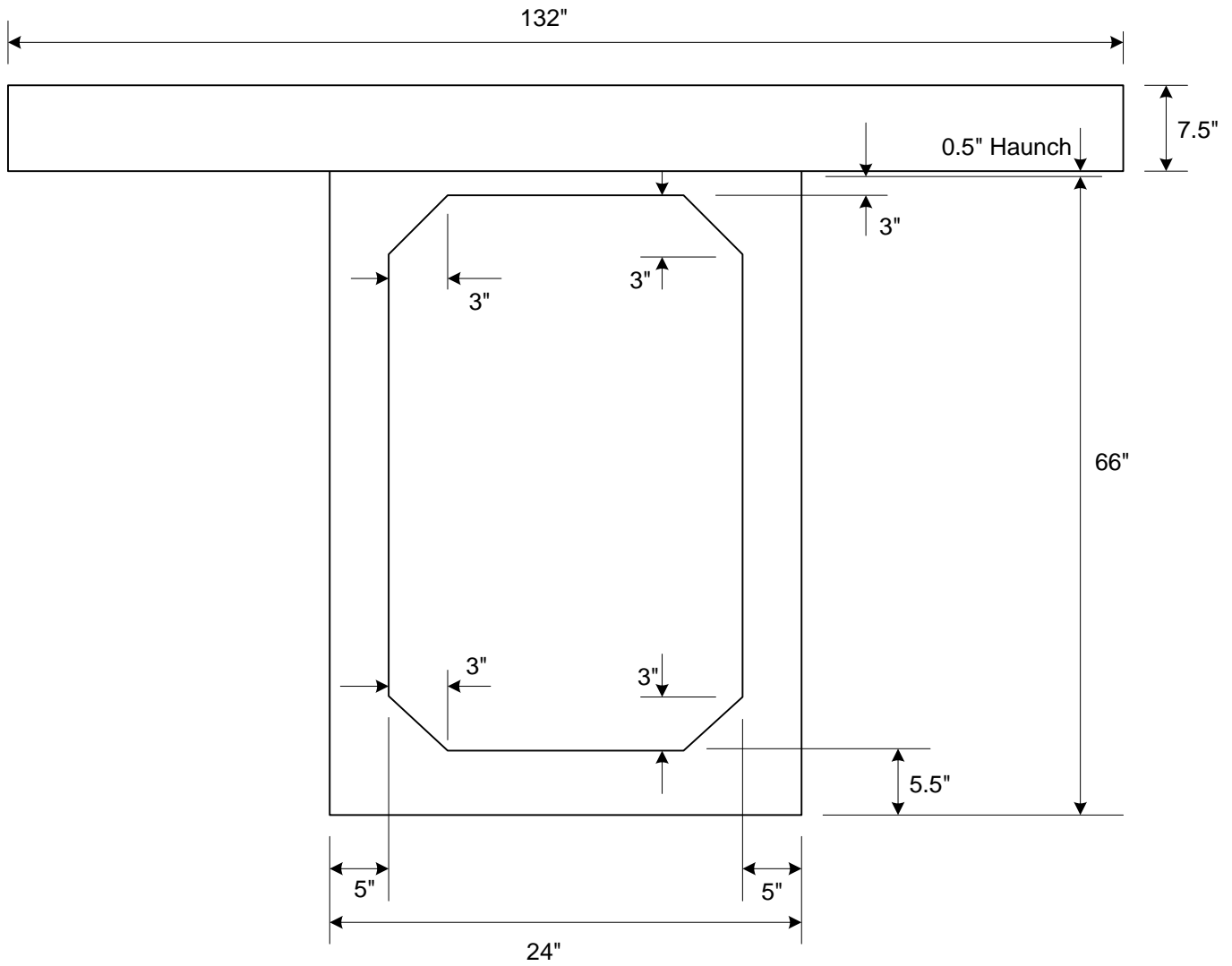

Composite Deck  
 $f'c(\text{slab}) = 4000 \text{ psi}$   
 $f'c(\text{beam}) = 6000 \text{ psi}$   
 Area P/S Strands =  $9.18 \text{ in}^2$   
 C.G. P/S Strands =  $10.133''$  (from bot. of beam)

Figure 7.5.1 - Section for Example 4

BSP  
BEAM SECTION PROPERTIES

PROJECT IDENTIFICATION	
1	2
#	EXAMPLE PROBLEM 2 - COMPOSITE PLATE GIRDER, NEGATIVE FLEXURE
#	
#	

SLAB DIMENSIONS AND PROPERTIES

UNITS	EFFECTIVE		SLAB F 'c	MODULAR RATIO	P/S CONC BEAM or RC SLAB DATA			FLEXURE OUTPUT	# OF SECT LOSS/ADD	NEGLECT CMFR	SLAB CONCRETE UNIT WEIGHT FOR E <sub>c</sub>	BEAM CONCRETE UNIT WEIGHT FOR E <sub>c</sub>	UNSYM FLANGE	INCL HAUNCH													
	WIDTH	THICK			HAUNCH	AREA P/S STR or TOP REINF	P/S STR or TOP REINF								C.G. P/S STR or TOP REINF	BEAM F 'c or Fy REINF											
1	2	3	19	25	27	29	37	43	49	50	51	53	54	60	66	67											
UP	1.3	2.0	7.5	0	5	4	0	0	0	0	0	0	0	6	9	1	8	0	1	0	1	3	3	6	0	0	0

STEEL BEAM DIMENSIONS AND PROPERTIES

SECT TYPE	WF BEAM OR I OR ANGLE VERT LEG	WF BEAM AREA OR ANGLE HORZ LEG	FLANGE OR ANGLE THICK	FLANGE WIDTH	WF BEAM OR WEB PLATE DEPTH	WF BEAM OR WEB PLATE DEPTH	WEB THICK	TOP PLATE THICK	TOP PLATE WIDTH	TOP PLATE THICK	BOTTOM PLATE THICK	BOTTOM PLATE WIDTH	BOTTOM PLATE THICK	COMPOSITE	Fy WEB	Fy TOP	Fy BOT
1	2	10	16	22	28	34	40	45	51	56	62	63	69	75			

UNSYMMETRICAL FLANGE

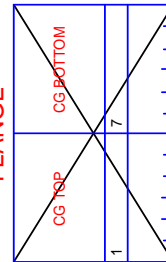

PREPARED BY .....

DATE ...../...../.....

SHEET ..... OF .....

Figure 7.5.2 - Input for Example 4

BSP  
BEAM SECTION PROPERTIES

PENNSYLVANIA DEPARTMENT OF TRANSPORTATION  
BUREAU OF INFORMATION SYSTEMS

P/S CONCRETE BEAM DIMENSIONS

TYPE	COMP	DESIG or D	W1	W2	W3	T1	T2	B1	B2	B3	B4	D1	D2	X1	X2
1	2	3	11	17	23	28	33	38	43	48	53	58	63	68	73
PY 4.8.6.6															

REINFORCED CONCRETE BEAM DIMENSIONS AND PROPERTIES

TYPE	DEPTH	WEARING SURFACE THICKNESS	TOP FLANGE WIDTH	TOP FLANGE THICKNESS	TOP FLANGE FILLET HORZ	TOP FLANGE FILLET VERT	TOP WEB THICKNESS	BOTTOM WEB THICKNESS	AREA BOTTOM REINF	DISTANCE TO BOTTOM REINF	BOTTOM FLANGE WIDTH	BOTTOM FLANGE THICKNESS	BOTTOM FLANGE FILLET HORZ	BOTTOM FLANGE FILLET VERT
1	2	8	13	19	25	30	35	41	47	53	59	65	71	76

PREPARED BY.....

DATE ...../...../.....

SHEET ..... OF .....

Figure 7.5.2 - Input for Example 4 (cont.)

## Chapter 7 Example Problems

### BEAM SECTION PROPERTIES

PROGRAM P4353050  
VERSION 2.0.0.0

LAST UPDATED 03/31/2015

03/25/2015 11:05  
DOCUMENTATION 03/2015

INPUT: EX4.DAT

EXAMPLE PROBLEM 4 - COMPOSITE PRESTRESSED CONCRETE SPREAD BOX BEAM

<<<<<<<<<< INPUT VALUES >>>>>>>>>>

SLAB DIMENSIONS AND PROPERTIES:

UNITS: U

MATERIAL: P

EFFECTIVE SLAB WIDTH: 132.00 (in)

EFFECTIVE SLAB THICKNESS: 07.50 (in)

EFFECTIVE SLAB HAUNCH: 00.50 (in)

SLAB F'c: 4000.0 (psi)

MODULAR RATIO (P/S Strands to Beam Concrete): 06

CONSTRUCTION MODULAR RATIO: N/A for P/S Beams

TOTAL AREA P/S STRANDS: 0009.180 (in<sup>2</sup>)

BOTTOM OF BEAM TO C.G. P/S STRANDS: 10.133 (in)

BEAM F'c: 006000 (psi)

FLEXURE: N/A for P/S Beams

OUTPUT: N/A for P/S Beams

NO. OF SECTION LOSS/ADDITION AND RIVET HOLE AREAS: N/A for P/S Beams

NEGLECT CMPR: N/A for P/S Beams

SLAB CONCRETE UNIT WEIGHT FOR Ec: 0.0000 (pcf)

BEAM CONCRETE UNIT WEIGHT FOR Ec: 0.0000 (pcf)

UNSYMMETRICAL FLANGE: N/A for P/S Beams

INCLUDE HAUNCH:

NOTE: Slab concrete unit weight assumed to be 145.0 pcf

Beam concrete unit weight assumed to be 145.0 pcf

P/S CONCRETE BEAM DIMENSIONS:

BEAM TYPE: B

COMPOSITE: Y

BEAM DESIGNATION: 48/66

D : 66.000 (in)

W1: 48.000 (in)

W2: 48.000 (in)

W3: 5.000 (in)

T1: 5.500 (in)

T2: 3.000 (in)

B1: 3.000 (in)

B2: 3.000 (in)

B3: 3.000 (in)

B4: 3.000 (in)

D1: 0.000 (in)

D2: 0.000 (in)

X1: 0.000 (in)

X2: 0.000 (in)

Figure 7.5.3 - Output for Example 4

## Chapter 7 Example Problems

<<<<<<<< COMPUTED VALUES >>>>>>>>>>

BASIC BEAM SECTION PROPERTIES (GROSS SECTION):

Moment of Inertia: 551125.17 (in<sup>4</sup>)  
N.A. to Top of Beam: 35.71 (in)  
N.A. to Bottom of Beam: 30.29 (in)  
Section Modulus of Beam Top: 15435.07 (in<sup>3</sup>)  
Section Modulus of Beam Bottom: 18192.58 (in<sup>3</sup>)  
St. Venant's Torsional Constant: 601931.66 (in<sup>4</sup>)

BASIC BEAM SECTION PROPERTIES (TRANSFORMED SECTION):

Moment of Inertia: 568963.90 (in<sup>4</sup>)  
N.A. to Top of Beam: 36.59 (in)  
N.A. to Bottom of Beam: 29.41 (in)  
Section Modulus of Beam Top: 15549.72 (in<sup>3</sup>)  
Section Modulus of Beam Bottom: 19345.92 (in<sup>3</sup>)

COMPOSITE BEAM SECTION PROPERTIES (GROSS SECTION):

Moment of Inertia: 1268868.56 (in<sup>4</sup>)  
N.A. to Top of Beam: 17.86 (in)  
N.A. to Top of Slab: 25.86 (in)  
N.A. to Bottom of Beam: 48.14 (in)  
Section Modulus of Beam Top: 71063.57 (in<sup>3</sup>)  
Section Modulus of Slab Top: 49075.57 (in<sup>3</sup>)  
Section Modulus of Beam Bottom: 26355.37 (in<sup>3</sup>)  
St. Venant's Torsional Constant: 832533.24 (in<sup>4</sup>)

COMPOSITE BEAM SECTION PROPERTIES (TRANSFORMED SECTION):

Moment of Inertia: 1333547.82 (in<sup>4</sup>)  
N.A. to Top of Beam: 18.80 (in)  
N.A. to Top of Slab: 26.80 (in)  
N.A. to Bottom of Beam: 47.20 (in)  
Section Modulus of Beam Top: 70949.10 (in<sup>3</sup>)  
Section Modulus of Slab Top: 49766.97 (in<sup>3</sup>)  
Section Modulus of Beam Bottom: 28250.64 (in<sup>3</sup>)

ADDITIONAL PROPERTIES:

Depth of Basic Beam: 66.00 (in)  
Area of Basic Beam: 1001.00 (in<sup>2</sup>)  
Area of Basic Beam + 1/4" of Conc. Around Void Perimeter: 1046.99 (in<sup>2</sup>)  
Weight of Beam per Unit Length (including 1/4"): 1.09 (k/ft)  
Volume of Basic Beam: 12012.00 (in<sup>3</sup>/ft)  
Surface Area of Basic Beam: 2736.00 (in<sup>2</sup>/ft)  
Volume / Surface Area Ratio: 4.390 (in)  
Longitudinal Stiffness Parameter: 2632230.38 (in<sup>4</sup>)  
Half-depth Area of Conc. Containing Pos. Flexure Tension Zone: 588.00 (in<sup>2</sup>)  
Half-depth Area of Conc. Containing Neg. Flexure Tension Zone: 1221.33 (in<sup>2</sup>)  
Area of Long. Mild Steel in Beam for Pos. Flexure: 0.00 (in<sup>2</sup>) \*  
Area of Long. Mild Steel in Beam for Neg. Flexure: 1.00 (in<sup>2</sup>) \* \*\*  
( 5 - #4 )

\* NOTE: The area of longitudinal steel should be reduced for lack of full development when appropriate.

\*\* NOTE: The area of longitudinal steel for negative flexure does not include steel in the slab.

Figure 7.5.3 - Output for Example 4 (cont.)

**7.6 EXAMPLE PROBLEM 5**

This is an example of a reinforced concrete T-beam. The dimensions and properties are specified in U.S. Customary units.

Figure 7.6.1 on page 7-26 shows the cross section of the steel member.

Figure 7.6.2 on page 7-27 shows the completed input data sheet.

Figure 7.6.3 on page 7-29 shows the output for this problem.

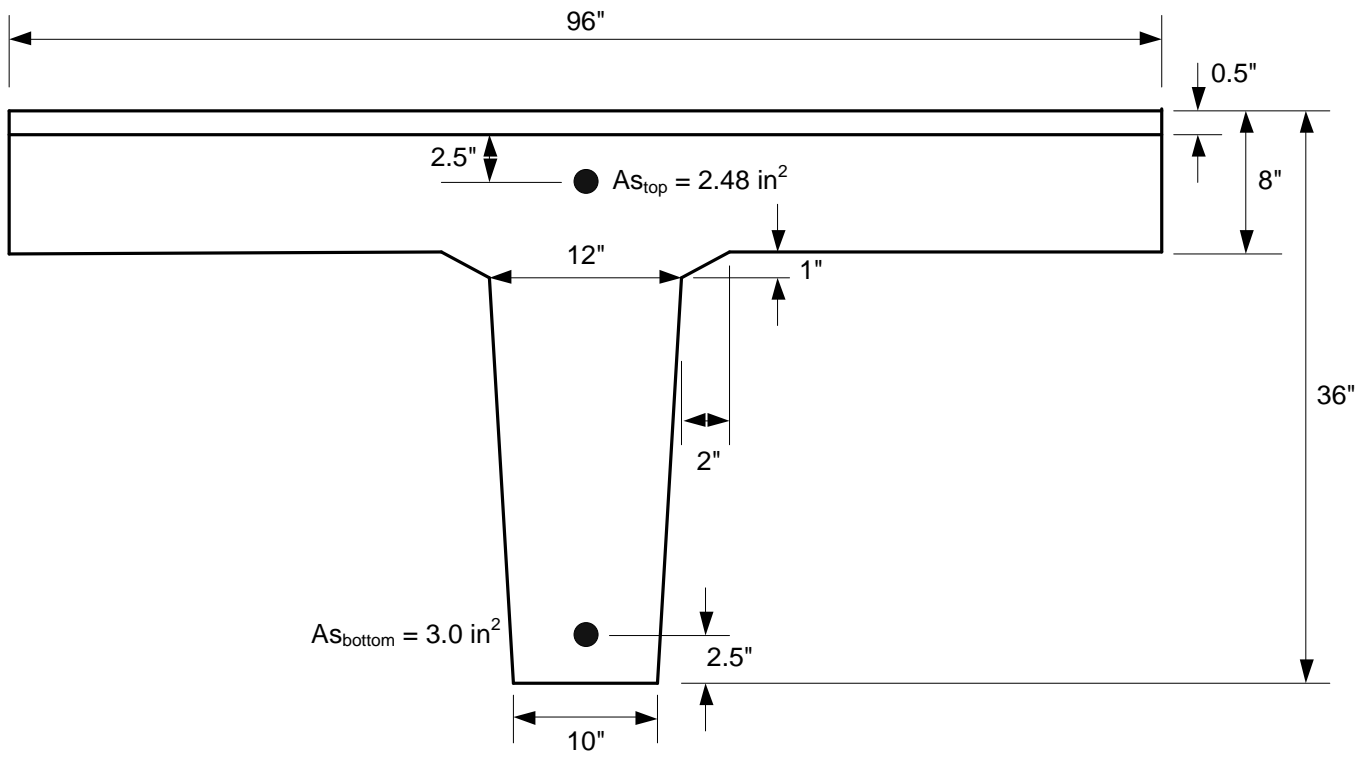

$f'_c = 3000 \text{ psi}$   
 $f_y = 60 \text{ ksi}$

Figure 7.6.1 - Section for Example 5

BSP  
BEAM SECTION PROPERTIES

PROJECT IDENTIFICATION	
1	2
#	EXAMPLE PROBLEM 5 - REINFORCED CONCRETE T-BEAM
#	
#	

SLAB DIMENSIONS AND PROPERTIES

UNITS	EFFECTIVE		SLAB F'c	P/S CONC BEAM or RC SLAB DATA				FLEXURE	LOSS/ADD	SLAB CONCRETE UNIT WEIGHT FOR E <sub>c</sub>	BEAM CONCRETE UNIT WEIGHT FOR E <sub>c</sub>	INCL HAUNCH	
	WIDTH	THICK		HAUNCH	AREA P/S STR or TOP REINF	C.G. P/S STR or TOP REINF	BEAM F'c or Fy REINF						# OF SECT
1	2	3	19	25	27	29	37	43	49	50	51	66	67
UR	9	6	3	0	0	1	0	2	4	8	0	0	0

STEEL BEAM DIMENSIONS AND PROPERTIES

SECT TYPE	WF BEAM OR ANGLE VERT LEG		WF BEAM OR ANGLE HORZ LEG		WF BEAM OR WEB PLATE DEPTH		WEB THICK		TOP PLATE		BOTTOM PLATE		Fy	Fy	Fy
	WIDTH	THICK	FLANGE OR ANGLE THICK	FLANGE WIDTH	PLATE DEPTH	WEB THICK	THICK	WIDTH	THICK	WIDTH	THICK	WEB			
1	2	10	16	22	28	34	40	45	51	56	62	63	69	75	
COMPOSITE															

UNSYMMETRICAL FLANGE

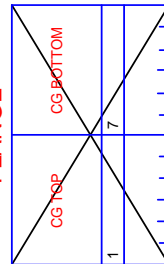

PREPARED BY .....

DATE .....

SHEET ..... OF .....

Figure 7.6.2 - Input for Example 5



Chapter 7 Example Problems

```

                                BEAM SECTION PROPERTIES

PROGRAM P4353050                                03/25/2015 14:02
VERSION 2.0.0.0                                LAST UPDATED 03/31/2015  DOCUMENTATION 03/2015

INPUT: EX5.DAT

EXAMPLE PROBLEM 5 - REINFORCED CONCRETE T-BEAM

<<<<<<<<<<  INPUT VALUES  >>>>>>>>>>

SLAB DIMENSIONS AND PROPERTIES:

UNITS: U
MATERIAL: R
EFFECTIVE TOP FLANGE/SLAB WIDTH: 000096 (in)
EFFECTIVE SLAB THICKNESS: N/A for RC Beam/Slab
EFFECTIVE SLAB HAUNCH: N/A for RC Beam/Slab
SLAB/BEAM CONCRETE F'c: 003000 (psi)
MODULAR RATIO (Reinf. Steel to Beam Concrete): 10
CONSTRUCTION MODULAR RATIO: N/A for RC Beam/Slab
AREA TOP REINF: 2.480000 (in^2)
C.G. TOP REINF: 2.5000 (in)
Fy REINF: 60000. (psi)
FLEXURE:
OUTPUT: 0
NEGLECT CMPR:
SLAB CONCRETE UNIT WEIGHT FOR Ec: N/A for RC Beam/Slab
BEAM CONCRETE UNIT WEIGHT FOR Ec: N/A for RC Beam/Slab
UNSYMMETRICAL FLANGE: N/A for RC Beam/Slab
INCLUDE HAUNCH: N/A for RC Beam/Slab

REINFORCED CONCRETE BEAM DIMENSIONS:

TYPE: T
DEPTH: 36.000 (in)
WEARING SURFACE THICKNESS: 0.500 (in)
TOP FLANGE WIDTH: 096.00 (in)
TOP FLANGE THICKNESS: 08.000 (in)
TOP FLANGE FILLET HORZ: 2.000 (in)
TOP FLANGE FILLET VERT: 1.000 (in)
TOP WEB THICKNESS: 12.000 (in)
BOTTOM WEB THICKNESS: 10.000 (in)
AREA BOTTOM REINF: 03.000 (in^2)
C.G. BOTTOM REINF: 02.500 (in)
BOTTOM FLANGE WIDTH: 0.0000 (in)
BOTTOM FLANGE THICKNESS: 0.0000 (in)
BOTTOM FLANGE FILLET HORZ: 0.000 (in)
BOTTOM FLANGE FILLET VERT: 0.000 (in)

```

Figure 7.6.3 - Output for Example 5

## Chapter 7 Example Problems

```
<<<<<<<< COMPUTED VALUES >>>>>>>>>

RC BEAM SECTION PROPERTIES:

GROSS SECTION:
(Tributary top flange/slab width and includes integral wearing surface)

Area: 1079.00 (in^2)
Depth: 36.00 (in)
N.A. to Top of Beam: 9.04 (in)
N.A. to Bottom of Beam: 26.96 (in)
Moment of Inertia: 92189.97 (in^4)

POSITIVE FLEXURE

CRACKED SECTION:
(Effective top flange/slab width and thickness)

Depth: 33.00 (in)
N.A. to Top of Beam: 4.07 (in)
N.A. to Bottom of Beam: 31.43 (in)
Moment of Inertia: 27381.90 (in^4)
Section Modulus to Extreme Compression (top) Fiber: 6731.96 (in^3)
Section Modulus to c.g. Tension (bot) Steel: 94.64 (in^3)
Section Modulus to c.g. Compression (top) Steel: 873.45 (in^3)
Moment Strength (phi Mn): 444.64 (k-ft)

NEGATIVE FLEXURE

CRACKED SECTION:
(Effective top flange/slab width and thickness)

Depth: 33.50 (in)
N.A. to Top of Beam: 27.77 (in)
N.A. to Bottom of Beam: 7.73 (in)
Moment of Inertia: 19089.32 (in^4)
Section Modulus to Extreme Compression (bot) Fiber: 2469.62 (in^3)
Section Modulus to c.g. Tension (top) Steel: 75.54 (in^3)
Section Modulus to c.g. Compression (bot) Steel: 182.51 (in^3)
Moment Strength (phi Mn): 380.07 (k-ft)
```

Figure 7.6.3 – Output for Example 5 (cont.)

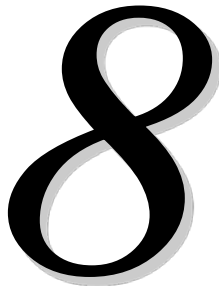

# ***TECHNICAL QUESTIONS AND REQUESTS***

This chapter contains reply forms to make it easier for users to convey their questions, problems or comments to the proper unit within the Department. General procedures for using these forms are given. Users should keep the forms in the manual as master copies, which can be reproduced as needed. They are also included as a Word template on the disk that has been provided for the program.

## **8.1 TECHNICAL QUESTIONS**

Technical questions related to the interpretations of the design specifications as implemented in this program, why certain assumptions are made, applicability and limitations of this program, and other questions not related to the operation of this program can be directed to the appropriate person in PennDOT using this form or the information provided on this form. Please review the information provided in this User's Manual and the references given in Chapter 1 before submitting this form for processing or calling for assistance. The completed form should be sent to the Bridge Quality Assurance Division (see form for complete address).

## **8.2 REVISION REQUESTS**

This form is to be used to report suspected program malfunctions that may require revisions to the program. It can also be used to request revisions that may be required due to changes in specifications and for the enhancement of the program. Unexpected or incorrect output, rejection of input data, endless program cycling, and program abortion are examples of program malfunctions. Users are requested to review their input data and the program User's Manual before submitting this form for processing.

This form may also be used to submit suggestions for improving the User's Manual for this program. Suggestions might include typographical error correction, clarification of confusing sections, expansion of certain sections, changes in format, and the inclusion of additional information, diagrams, or examples.

The completed form should be sent to the Engineering Unit via mail, fax, or e-mail.

This page is intentionally left blank.

# BSP

## TECHNICAL QUESTIONS

This form is to be used to ask questions on technical issues related to this engineering program. Questions on the interpretations of the design specifications as implemented in this program, why certain assumptions are made by the program and other questions not related to the operation of this program may be submitted using this form or by calling the telephone number listed in this form. Users are requested to review their input data and read the User's Manual and LRFD Specifications before submitting this form or calling to ask questions.

CONTACT PERSON: \_\_\_\_\_ DATE: \_\_\_\_\_  
ORGANIZATION: \_\_\_\_\_ PHONE: \_\_\_\_\_  
E-MAIL ADDRESS: \_\_\_\_\_ FAX: \_\_\_\_\_  
PROGRAM VERSION: \_\_\_\_\_

Clearly state your question(s) and attach documentation you feel would be helpful in answering your question(s). If you require more space, use additional 8½ x 11 sheets of plain paper.

FORWARD COMPLETED FORM TO: Pennsylvania Dept. of Transportation  
Bridge Design and Technology Division  
Commonwealth Keystone Building, 7<sup>th</sup> Floor  
400 North Street  
Harrisburg, PA 17120-0094  
PHONE: (717) 787-2881  
FAX: (717) 787-2882

RECEIVED BY: \_\_\_\_\_ FOR DEPARTMENT USE ONLY  
ASSIGNED TO: \_\_\_\_\_ DATE: \_\_\_\_\_

This page is intentionally left blank.

# BSP REVISION REQUEST

This form is to be used to report suspected program malfunctions, or to request revisions to the program or its documentation. Users are requested to review their input data and the program User's Manual before submitting this form.

CONTACT PERSON: \_\_\_\_\_ DATE: \_\_\_\_\_  
ORGANIZATION: \_\_\_\_\_ PHONE: \_\_\_\_\_  
E-MAIL ADDRESS: \_\_\_\_\_ FAX: \_\_\_\_\_  
PROGRAM VERSION: \_\_\_\_\_

Define your problem and attach samples and/or documentation you feel would be helpful in correcting the problem. If the input data is more than 4 or 5 lines, Licensees should provide the input data file on a diskette. If you require more space, use additional 8½ x 11 sheets of plain paper.

FORWARD COMPLETED FORM TO: Pennsylvania Department of Transportation  
Bureau of Business Solutions and Services  
Engineering Software Section  
Commonwealth Keystone Building, 5<sup>th</sup> Floor  
400 North Street  
Harrisburg, PA 17120-0041  
PHONE: (717) 787-8407 / (717) 783-8822  
FAX: (717) 705-5529  
E-MAIL: penndotbisengineer@pa.gov

RECEIVED BY: \_\_\_\_\_ FOR DEPARTMENT USE ONLY  
ASSIGNED TO: \_\_\_\_\_ DATE: \_\_\_\_\_

This page is intentionally left blank.

